

IDS Xwave Training Manual



SOUTH AFRICA'S LEADING MANUFACTURER AND DISTRIBUTOR OF
ELECTRONIC SECURITY PRODUCTS

Xwave 8 Channel Standalone Wireless Receiver

The IDS Xwave 8 Channel Standalone Wireless Receiver is capable of learning up to 8 IDS Xwave detectors. The receiver has 8 zone outputs and 3 trouble outputs. In this guide we will discuss all functions as well as installation and programming of the receiver.



1. Installation

1.1. Hardware

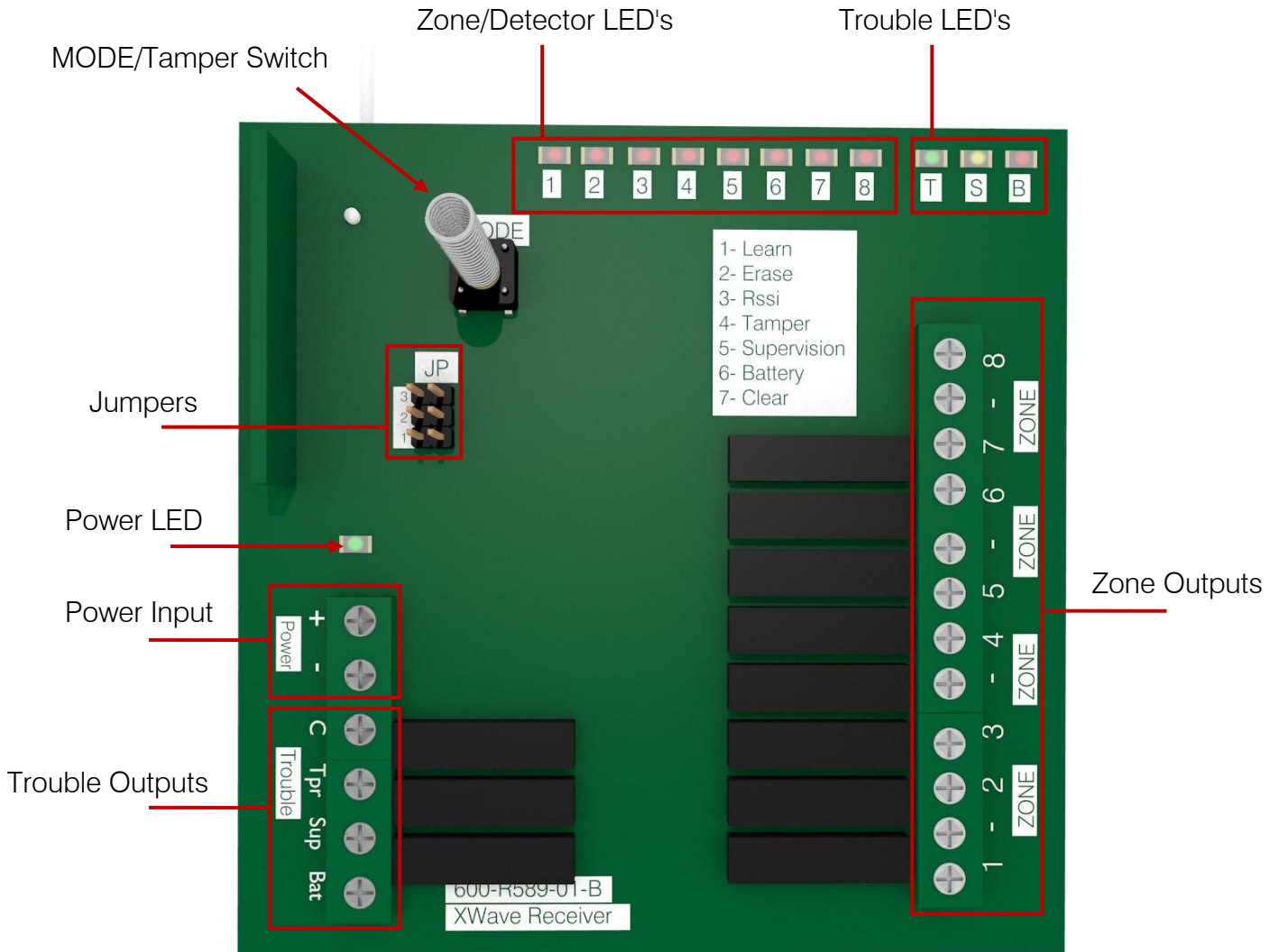

1.2. Jumpers

The IDS Xwave 8 Channel Standalone Wireless Receiver has 3 jumpers that allow you to set the supervision time, enable tamper and enable RF Jam detection.

JP 1 - Supervision Time	
ON	Supervision Time is set to 3 hours.
OFF	Supervision Time is set to 24 hours.

The Supervision Time is the amount of time the receiver will wait for a supervision signal from the detector. If no supervision signal is received a Supervision failure will be created.

JP 2 - RF Jam Detection	
ON	Enables RF Jam detection.
OFF	Disables RF Jam detection.

When RF Jam Detection is enabled it uses Zone output 8 when an RF jam is detected. If RF Jam Detection is enabled then detector 8 is disabled.

JP 3 - Box Tamper	
ON	Enables Box Tamper.
OFF	Disables Box Tamper

The tamper button is also used to program the receiver, when programming the receiver JP 3 must be off.

1.3. Trouble Outputs

There are 3 trouble outputs, excluding zone 8 when using RF Jam Detection. These outputs include Tamper, Low Battery and Supervision. When the IDS Xwave 8 Channel Standalone Wireless Receiver receives a trouble condition it will trigger the corresponding output until it has received a restoral for that trouble.

1.4. Zone Outputs

There are 8 zone outputs numbered 1 - 8 for each learned detector, these outputs are triggered when the receiver gets a signal from the corresponding detector. The outputs should be wired to the zone of an alarm panel.

If RF Jam Detection is enabled then output 8 is triggered when the receiver detects an RF jam, and will ignore any signals from detector 8.

1.5. LEDs

The IDS Xwave 8 Channel Standalone Wireless Receiver uses LEDs to indicate what is happening on the receiver.

Power LED - This LED is on when the receiver is powered.

Zone LEDs - LEDs 1 - 8 will light up when the receiver has received a signal from the corresponding detector, and to indicate which menu option has been chosen.

RF Jam LED - Zone LED 8 will come on when the receiver has detected an RF Jam.

Tamper LED - This LED will come on if the receiver gets a tamper signal from one of the learned detectors, or if the box tamper has been triggered. The LED will turn off once it has received a tamper restoral from the tampered detector.

Supervision - This LED will come on if the receiver has not received a signal from a specific detector within the Supervision time. The LED will turn off once the receiver has received a signal from that detector.

Low Battery - This LED will turn on if the receiver gets a low battery signal from a detector. The LED will turn off once it receives a battery restoral from that same detector.

2. Modes

To program the IDS Xwave 8 Channel Standalone Wireless Receiver ensure that jumper 3 is off, so that the tamper switch becomes the MODE button. Programming is done by holding the MODE button down, the zone LEDs will light up one at a time starting from 1 up until 8. Release the MODE button when the LED reaches the mode you need. After 2 minutes of inactivity the receiver will return to normal operation.

2.1. Mode 1 - Learn

Mode 1 is used to learn detectors into the IDS Xwave 8 Channel Standalone Wireless Receiver.

To learn a detector to the IDS Xwave 8 Channel Standalone Wireless Receiver:

- 1.) Hold the MODE button until LED 1 is lit, then release it.
- 2.) Choose the channel you want to learn the detector to, this is done by holding the MODE button again until the desired LED is lit.
(If there is already a detector learned to that channel the LED will begin flashing. You can learn a new detector to replace the existing one)
- 3.) Press the tamper on the detector you want to learn to the selected channel. When the detector has been learned all zone LEDs will flash momentarily.
- 4.) You can learn another detector by pressing the MODE button until the desired LED is lit and repeating the process.

2.2. Mode 2 - Erase

Mode 2 is used to erase detectors from the IDS Xwave 8 Channel Standalone Wireless Receiver.

To erase a detector from the IDS Xwave 8 Channel Standalone Wireless Receiver:

- 1.) Hold the MODE button until LED 2 is lit, then release it.
- 2.) Choose the channel you want to erase the detector from, this is done by holding the MODE button again until the desired LED is lit.
(If there is a detector learned to that channel the LED will begin flashing)
- 3.) After approximately 10 seconds all zone LEDs will flash momentarily. This indicates that the detector in selected channel has been erased.
- 4.) You can erase another detector by pressing the MODE button until the desired LED is lit and repeating the process.

2.3. Mode 3 - RSSI

RSSI mode is used to test the signal strength of a detector.

To check the signal strength of a detector on the IDS Xwave 8 Channel Standalone Wireless Receiver:

- 1.) Hold the MODE button until LED 3 is lit, then release it.
- 2.) Choose the channel you want to check the signal strength of, this is done by holding the MODE button again until the desired LED is lit.
- 3.) Trigger the detector learned to the selected channel. The zone LEDs will light up proportional, to that detectors signal strength.
(The LEDs light from left to right, so if only two LEDs on the left are illuminated your signal is poor, if you have 6 LEDs illuminated your signal is good)
- 4.) You can check the signal strength of another detector by pressing the MODE button until the desired LED is lit and repeating the process.

2.4. Modes 4, 5 and 6 - Troubled Zones

If you receive a trouble condition; tamper, supervision loss or low battery, you can see which zones have sent these troubles by using modes 4, 5 and 6.

Mode 4 - Shows tampered zones

Mode 5 - Shows supervision failed zones

Mode 6 - Shows low battery zones

To show the troubled zones on the IDS Xwave 8 Channel Standalone Wireless Receiver:

1.) Hold the MODE button until LED 4, 5 or 6 is lit, then release it.
All LEDs with the selected trouble will come on.

2.5. Mode 7 - Clear Troubles

If you want to clear any troubles that are displayed on the IDS Xwave 8 Channel Standalone Wireless Receiver:

1.) Hold the MODE button until LED 7 is lit, then release it.
All zone LEDs will flash momentarily to indicate that all troubles, tamper, supervision and low battery will be cleared.

IDS Xwave Door Contact

The 860-07-587 door contact has a built-in wireless transmitter.

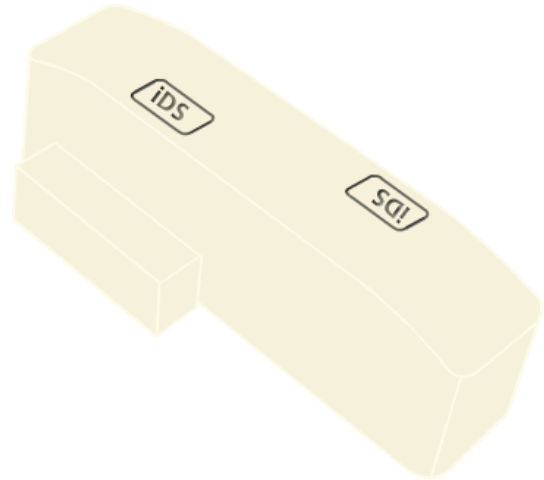

3. Hardware

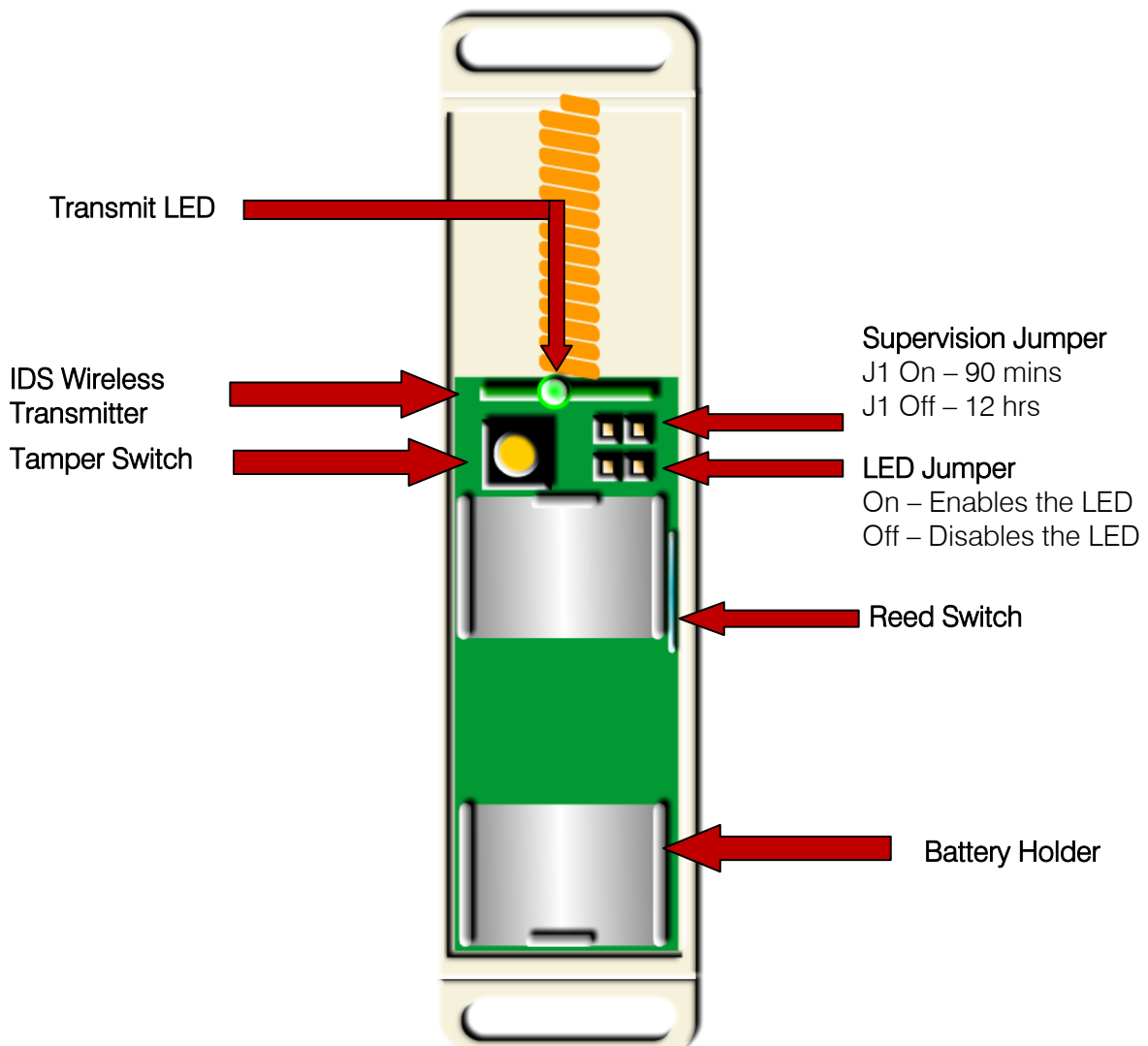

4. Installation

Mount the wireless door contact to the door frame via the mounting holes. (Making sure that the base does not extrude passed the frame and catch on the door when it opens or closes.)

Close the door and mount the magnet onto the door next to the reed switch. (Make sure that the magnet does not interfere with the wireless door contact when opening and closing the door. Make sure that when opening the door the magnet moves a sufficient distance away from the reed switch to activate the wireless door contact)

Set the jumper settings (seen in the Hardware section) to your needs.