

# IDS 805

---

## Installer Manual

South Africa's leading manufacturer and distributor of electronic security products.





# Content

<b>1.</b>	<b>Introduction to the IDS 805.....</b>	<b>7</b>
1.1	Features .....	7
<b>2.</b>	<b>Installation and Wiring.....</b>	<b>8</b>
<b>3.</b>	<b>End-of-Line Resistors/Tamper per Zone .....</b>	<b>9</b>
<b>4.</b>	<b>Connecting the Telephone Communicator .....</b>	<b>10</b>
<b>5.</b>	<b>Programmable Outputs.....</b>	<b>10</b>
<b>6.</b>	<b>The Key-switch or Remote Control Unit .....</b>	<b>10</b>
<b>7.</b>	<b>Additional Technical Data.....</b>	<b>11</b>
<b>8.</b>	<b>Hardware Reset Switch .....</b>	<b>11</b>
<b>9.</b>	<b>Event Log.....</b>	<b>12</b>
<b>10.</b>	<b>Dialler Progress Mode .....</b>	<b>12</b>
<b>11.</b>	<b>Download Code .....</b>	<b>13</b>
<b>12.</b>	<b>Programming Instructions .....</b>	<b>13</b>
12.1	Introduction .....	13
12.2	Location Values .....	13
12.3	Programming the Panel .....	14
12.4	Program Location Summary .....	15
<b>Index</b>	<b>.....</b>	<b>44</b>

## Figures

Figure 1: Connection Diagram.....	8
Figure 2: Tamper per Zone Connection.....	9
Figure 3: Resistors Used for Tamper per Zone.....	9
Figure 4: Programmable Output Configuration.....	10
Figure 5: Strobe Output Sequence.....	24
Figure 6: Fire Detect Output Sequence.....	24

## Tables

Table 1: Dialler Progress as Shown by Zone LED's.....	12
Table 2: Value Represented by Each Zone Indicator.....	13
Table 3: Binary Representation.....	14
Table 4: Location/Zone Defaults.....	15
Table 5: Programmable Zone Types.....	16
Table 6: Output Options.....	22
Table 7: Output Options Default Values.....	23
Table 8: Standard Contact ID Reporting Codes.....	27
Table 9: Alarm Reporting Codes.....	28
Table 10: Trouble Conditions.....	39

# CONTROL KEYPAD

For a more detailed explanation of the keypad indicators see understanding the Keypad Indicators.

## ARMED INDICATOR (RED)

The indicator is illuminated when the system is armed in the AWAY mode.

## READY INDICATOR (GREEN)

The indicator is illuminated when the system is ready to be armed.

## POWER INDICATOR (RED)

The indicator is illuminated when mains power is present.

## ZONE INDICATOR (ORANGE)

Indicates the status of the zones.

## STAR KEY

Used to program bypass zones, and used as an entry key for data input.

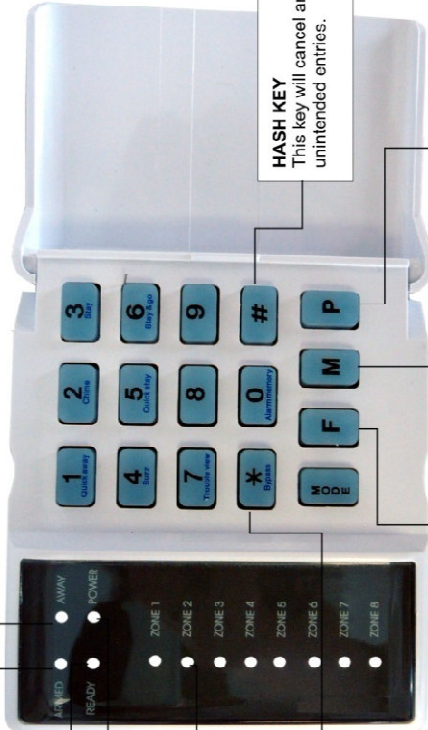

## HASH KEY

This key will cancel any unintended entries.

## FIRE ALARM

This key will activate the FIRE ALARM when held down for one second.

## MEDICAL ALARM

This key will activate the MEDICAL ALARM when held down for one second.

## PANIC ALARM

This key will activate the PANIC ALARM when held down for one second.

# CONTROL KEYPAD

For a more detailed explanation of the keypad indicators see understanding the Keypad Indicators.

**ARMED INDICATOR (RED)**  
The indicator is illuminated when the system is armed.

**READY INDICATOR (GREEN)**  
The indicator is illuminated when the system is ready to be armed.

**ZONE INDICATOR (ORANGE)**  
Indicates the status of the zones.

**AWAY INDICATOR (RED)**  
The indicator is illuminated when the system is armed in the AWAY mode.

**POWER INDICATOR (RED)**  
The indicator is illuminated when mains power is present.

**PANIC ALARM**  
This key will activate the PANIC ALARM when held down for one second.

**FIRE ALARM**  
This key will activate the FIRE ALARM when held down for one second.

**MEDICAL ALARM**  
This key will activate the MEDICAL ALARM when held down for one second.

**STAR KEY**  
Used to program bypass zones, and used as an entry key for data input.

**HASH KEY**  
This key will cancel any unintended entries.

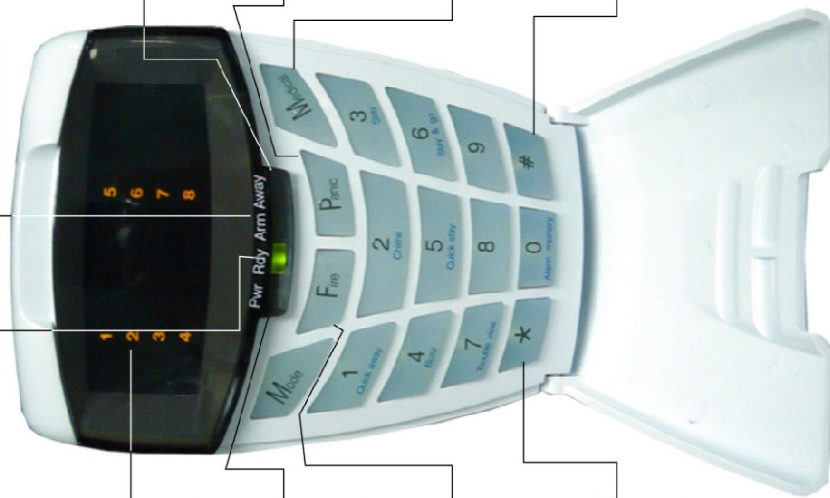

# 1.

## Introduction to the IDS 805

The IDS 805 is a versatile, state of the art, microprocessor based, eight-zone Alarm Panel. Most features are optional and may be programmed either directly through the keypad or via the telephone system, using the IDS download software and appropriate modem. There are eight programmable burglary zones, appropriate siren, auxiliary power outputs and 5 outputs which may be programmed to perform various trigger/switching functions.

For correct operation, the IDS 805 must be used in conjunction with the specified transformer/battery combination and appropriate peripheral sensors and signalling devices.

### 1.1

### Features

- Bylaw 25 compliant
- Four wire keypad operation - up to a maximum of 4 keypads.
- Eight, fully programmable, end-of-line (3K3) supervised zones, and 1 dedicated panic zone per keypad which is not end-of-line supervised.
- Telephone line and siren monitoring.
- Optional tamper and box tamper reporting per zone using double end-of-line resistors (12K and 4K7).
- Fully programmable digital telephone communicator which supports most industry standard formats.
- Five programmable trigger outputs.
- Non-volatile EEPROM memory retains all program and event log data in the event of a total power failure.
- Programmable loop response time for all zones (global).
- Up and downloadable using IDS windows based software.
- Excellent protection against lightning (provided by specialised zap tracking and transient suppressors).
- Auto arm - panel can be programmed to arm daily at a predetermined time.
- Event log (200 events) date and time stamped.
- Fax defeat allows download access to the panel with other devices connected to the phone line.
- Dual reporting provides for duplicated reporting to two independent central base stations.
- Programmable silent or audible panic.
- Unique dialler progress bar allowing for monitoring of dialler status.

## 2.

# Installation and Wiring

Please refer to Figure 1: Connection Diagram and familiarise yourself with the following sections.

**Figure 1: Connection Diagram - without tamper per zone**

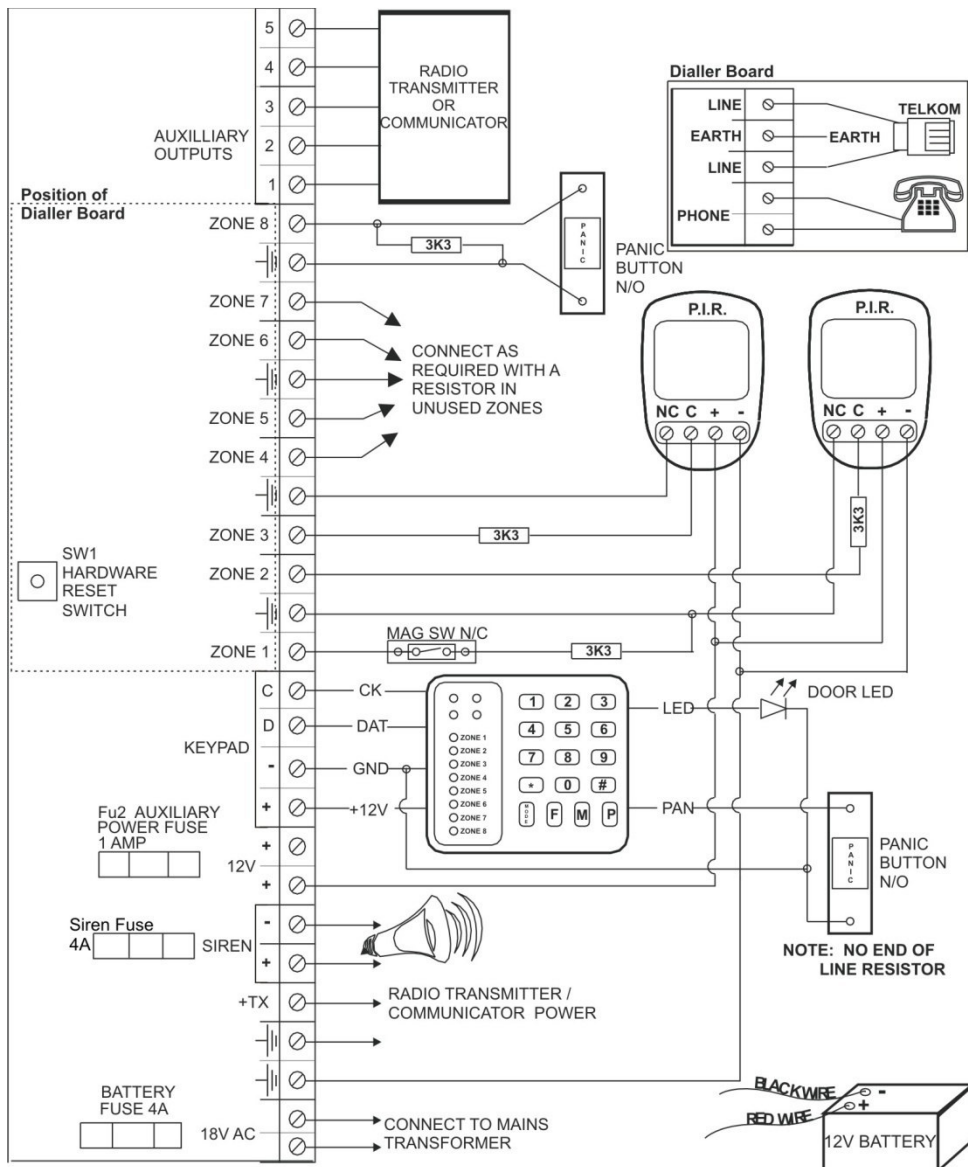



### 3.

## End-of-Line Resistors/Tamper per Zone

- All zones are end-of-line supervised. Any unused zones must also be terminated with the appropriate resistor.
- The end of line resistor should be placed inside or as close to the sensor as possible.
- If the zones are not programmed to report tamper by zone i.e. a [0] is programmed into location 11 then use the 3K3 end-of-line resistor.
- If the zones are programmed to report tamper by zone, the 4K7 and 12K end-of-line resistors should be connected as per Figure 2 below. The 4K7 and 12K resistors are not included with the panel but may be obtained from your local distributor of IDS products.

**Figure 2: Tamper per Zone Connection**

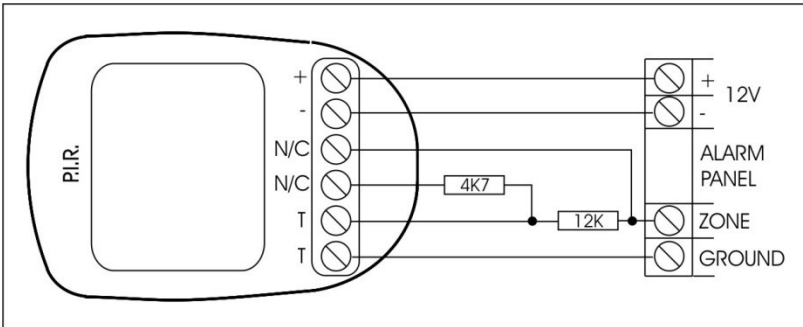

The operation of the tamper is as follows:

- If the panel is not armed and a tamper condition occurs, the siren will not sound but a tamper condition will be reported.
- If the panel is armed and tamper condition occurs the alarm will register a zone violation and a tamper condition will be reported.
- Regardless of whether the panel is armed or not, if a zone is programmed as a priority/panic zone, a tamper will register a panic condition as well a tamper condition.
- If the tamper per zone is enabled, it affects all zones and therefore both end-of-line resistors must be connected in all zones. If the tamper facility is not used on a zone then the 12K resistor must be connected directly across the zone (i.e. between the zone input and ground) and the 4K7 resistor is used as the normal end-of-line resistor.
- The colour codes for the 12K and 4K7 resistors are as seen in Figure 3 below.

**Figure 3: Resistors Used for Tamper per Zone**

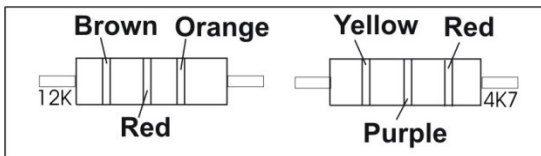

## 4. Connecting the Telephone Communicator

Refer to Figure 1.

- The integral communicator has built in lightning protection to protect it from lightning induced transients. For optimum protection, connect a low impedance earth to the communicator. A poor earth will be ineffective and may result in damage to the communicator and Alarm Panel.
- Always connect the telephone communicator in the line seizure mode. Never in parallel with the telephone, i.e. connect the telephone receiver to the communicator terminals marked phone and the incoming line to the terminals marked line.

## 5. Programmable Outputs

A relay board must be used when any device requiring a high current is connected to a programmable output. The current sink and source capability is the same for outputs 1 to 5. The output circuitry consists of a 12-volt source with a  $56\Omega$  series resistor. Current sink is via a  $1,000\Omega$  resistor to negative. The output circuitry is provided in Figure 4.

Figure 4: Programmable Output Configuration

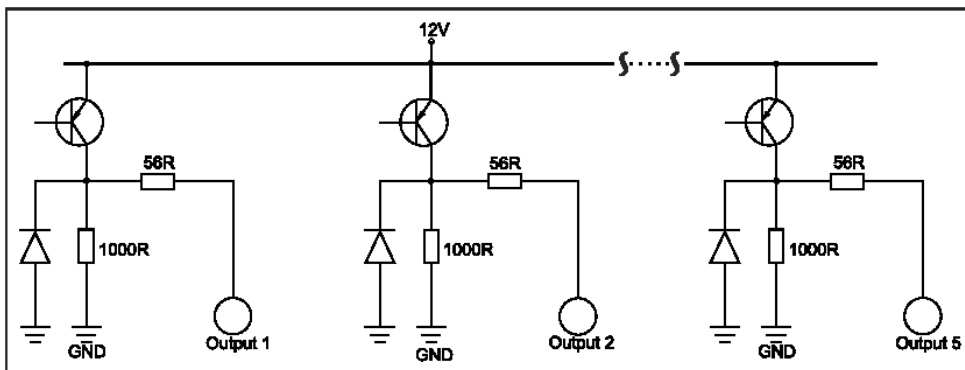

## 6. The Key-switch or Remote Control Unit

A momentary key-switch or non-latching remote control receiver may be connected to any zone to allow remote arm/disarm capability and/ or remote panic.

- If a key-switch or remote control unit is used, a  $3K3$  resistor must be connected between the zone input and ground. (Use the  $4K7$  and  $12K$  resistors if tamper per zone is enabled).
- Use a normally open, *spring-loaded momentary* key-switch or a *non-latching* remote control unit. The remote receiver must provide a pulsed output.
- If using a key-switch, program the zone as an Arm/Disarm zone i.e. a value of **[5]** entered into the relevant location.
- If using a remote control, program the zone as either a Panic zone or an Arm/Disarm zone, as required.
- The panel will arm instantly (no entry/exit delay) when arming by means of a key-switch or remote control unit.

- The panel has an exit delay which can be enabled or disabled with the key-switch or remote control (See location 12).

## 7. Additional Technical Data

- Use a suitable transformer with an output voltage of between 15V and 18V with a 16VA minimum rating. A 32 VA transformer is preferable for larger installations.
- Use a 12V sealed lead acid battery, min. 3ah. The backup period after mains failure will depend on the number of keypads, sensors, and peripheral devices attached to the system. The current drawn by the panel and keypad (no indicators lit) excluding sensors is 240mA.
- The panic zone provided on the keypad is not an end-of-line supervised zone and requires a normally open panic switch. If using this panic zone connect a normally open panic switch between the PAN terminal and the GND terminal. If this zone is not used, leave the terminal open circuit.
- The box tamper is not end-of-line supervised and a N/C contact indicates a closed box.
- A door LED may be connected to the keypad. This LED will mimic the ARM LED on the keypad i.e. When the system is not armed the LED will be off. If the system is armed, the LED will be on and will flash if an alarm condition was registered while the system was armed. Note that the anode of the LED connects to the LED terminal on the keypad and the cathode of the LED is connected to the GND terminal. No series resistor is required.
- Do not connect more than 8 PIR's and two keypads, (or 6 PIR's and 3 keypads) to the auxiliary 12-volt outputs.
- The siren output requires a self-driven 12-volt siren. The siren minus terminal is connected to ground. The positive terminal of the siren is connected to 12 volts via a relay during the siren period.
- A full description of each programmable function of the panel is contained in the section headed Program Location Summary.
- All information regarding the programming of user codes, home zones delayed interior zones and chime zones is contained in the User Manual.
- If a radio transmitter or voice message communicator is being used for monitoring purposes the power for these devices should be taken from the "+TXT" terminal.

### NOTE:

The TX+ terminal is protected by means of the battery fuse. If excessive current (2 amps max) is drawn from this terminal, battery power to the alarm may be lost.

## 8. Hardware Reset Switch

In the event that the installer code is lost, it is possible to reset the panel to its factory default values using the hardware reset switch labelled SW1 on the main PC board. Provided that the reset switch has not been disabled (see location 21), the panel may be defaulted by removing both battery and AC power from the panel, and then reapplying the power (AC/battery) while depressing the switch. Factory default values will be restored to all locations.

### NOTE:

If the reset switch has been disabled, it is *not possible* to default the panel using the reset switch. The panel may *only* be defaulted if a valid installer code is used and a value of **[0]** is entered into location 0.

**9.****Event Log**

The IDS 805 automatically keeps an internal log of all events which may be communicated through the onboard communicator. 200 of the most recent events will be retained. Once the event log is "full", the oldest event will be overwritten by the most recent event. An event is logged regardless of whether or not the panel is programmed to communicate the event.

The event log can only be retrieved by means of the Windows based download/upload software and appropriate modem.

The time of each event is not logged in absolute terms i.e. time of day and date but relative to the previous event. The date and time indicated on an uploaded event log is calculated by the PC using the PC clock time. Since the time at which the upload event was initiated is known, all other times can be calculated relative to this event.

The IDS 805 does not contain an onboard battery to maintain the clock time in the event of a total power failure (AC mains failure and discharged battery) therefore in the event of a total power failure it will not be possible to calculate the absolute time at which an event took place. The relative time of each event will still be indicated

**10.****Dialler Progress Mode**

When the panel sends data to a central station, the keypad zone LED's may be used to display the "progress" of such communication. To view the communication status, proceed as follows:

1. Hold down the **[0]** key until the keypad buzzer sounds once.
2. Press the **[9]** key. The ARMED, READY and AWAY LED's will flash simultaneously indicating that the Dialler Progress Mode has been selected. Using the zone indicators, the following table will provide the communication status.
3. To exit this mode, press the **[#]** key.

**Table 1: Dialler Progress as Shown by Zone LED's**

<b>Zone LED</b>	<b>Standby</b>	<b>Seizing Line</b>	<b>Dialling Base Station</b>	<b>Waiting for Kiss-on</b>	<b>Sending Data</b>	<b>Waiting for Kiss-off</b>	<b>Waiting for Next Dial Attempt</b>
<b>Zone 1</b>	*	*	*	*	*	*	*
<b>Zone 2</b>	●	*	*	*	*	*	●
<b>Zone 3</b>	●	●	*	*	*	*	●
<b>Zone 4</b>	●	●	●	*	*	*	●
<b>Zone 5</b>	●	●	●	●	*	*	●
<b>Zone 6</b>	●	●	●	●	●	*	●
<b>Zone 8</b>	●	●	●	●	●	●	*

● Off

\* On

## 11.

## Download Code

A download code is used for download access. The default download code is **9999**. Via the downloading it is possible to set a location to either allow or disallow defaulting of the download code. The location is only accessible using the download software. If selected to allow defaulting of the download code, the download code will be defaulted to 9999 if the panel is defaulted. A value of **[10]** programmed into this location prevents the download code from being defaulted.

This function may only be used with download software version 1.4.0 or later.

## 12.

## Programming Instructions

### 12.1

### Introduction

The panel may be programmed either using the keypad or using the up/download software. Programming the panel by means of the keypad is explained in the following sections of this manual. For information on programming the panel using the up/download software refer to the manual pertaining to the software.

#### **NOTE:**

Before commencing the programming, it is advisable to read the Installer Manual thoroughly.

### 12.2

### Location Values

All values within a program location are displayed by the zone indicators in binary format. The table below indicates how these values may be read.

**Table 2: Value Represented by Each Zone Indicator**

<b>Zone 1</b>	1
<b>Zone 2</b>	2
<b>Zone 3</b>	4
<b>Zone 4</b>	8

To read a binary value on the keypad add the values represented by each lit LED. The total value is the number being represented e.g. assume the following zone indicators are on: Zone 1, Zone 3, and Zone 4. The value would be as shown in the table below.

<b>Zone 1</b>	1
<b>Zone 3</b>	4
<b>Zone 4</b>	8
Total	<b>13</b>

**Table 3: Binary Representation**

Value	0	1	2	3	4	5	6	7	8	9	10	11	12	13	14	15
<b>Zone 1 (20=1)</b>	●	*	●	*	●	*	●	*	●	*	●	*	●	*	●	*
<b>Zone 2 (21=2)</b>	●	●	*	*	●	●	*	*	●	●	*	*	●	●	*	*
<b>Zone 3 (22=4)</b>	●	●	●	●	*	*	*	*	●	●	●	●	*	*	*	*
<b>Zone 4 (23=8)</b>	●	●	●	●	●	●	●	●	*	*	*	*	*	*	*	*

● Off

\* On

## 12.3 Programming the Panel

- For all programming procedures, the [\*] (star) key functions as the enter key and the [#] (hash) key functions as a clear key to clear incorrect or unintended entries, as a backspace and to exit the programming mode.
- If an error has been made, i.e. an attempt is made to enter an illegal value or an incorrect series of keystrokes, the keypad will beep three times to indicate the error. The panel will automatically discard the invalid entry allowing the correct entry to be made without manually clearing the incorrect entry.

### Procedure:

1. Ensure that the panel is not armed.
2. Press the [#] key (this will clear any previous or accidental entries) followed by the 4 digit **[INSTALLER CODE]** (the default installer code is 9999).
3. If the correct code has been entered, the green READY indicator will begin flashing.
4. Press the [\*] key.
5. Enter the **[LOCATION NUMBER]** of the program location that you wish to change. Location is displayed in binary.
6. Press the [\*] key. The READY indicator will continue flashing and the AWAY indicator will come on.
7. The zone LED's will now display the content of the selected program location in binary format (ref. Table 3).
8. If you wish to change the content of the location, enter the **[NEW VALUE]** followed by the [\*] key. If you do not wish to change the location value, press the [#] key. The READY indicator will continue flashing and the AWAY indicator will turn off.
9. If the data value has been changed, the buzzer will give a long beep indicating that a valid entry has been stored.
10. Repeat steps 5-8 until all necessary locations have been programmed.
11. To exit from the programming mode press the [#] key.

The READY indicator will stop flashing to indicate that the program mode has been exited.

**12.4****Program Location Summary**

Following is a detailed description of the functioning of each location and its options.

<b>LOCATION 0</b>	<b>Defaulting of the Panel or Master User Code</b>
-------------------	--

<b>Value</b>	<b>Action</b>
0	Resets all locations to the factory default values as shown in the DEFAULT column in the programming list. All user codes will also be defaulted and the master code will become 1234.
1	Will default the master user code to 1234 without defaulting the remainder of the user codes. All other information will remain unaltered.
2	Will reset all reporting codes to 0. If a communicator format other than Contact ID is used, the reporting codes need to be reprogrammed. It is advisable to default all reporting codes to 0 prior to reprogramming the codes.

<b>LOCATIONS 1-8</b>	<b>Zone Characteristics (Zones 1-8)</b>
----------------------	---

Program locations 1 to 8 define the zone characteristics of each of the eight zones. Each zone can be programmed to function in one of eleven modes. Table 4 provides a location/zone cross-reference together with the default zone characteristics.

**Table 4: Location/Zone Defaults**

<b>Loc</b>	<b>Zone</b>	<b>Default</b>	<b>Zone Type</b>
1	1	1	Entry/Exit
2	2	2	Follower
3	3	4	Audible Instant
4	4	4	Audible Instant
5	5	4	Audible Instant
6	6	4	Audible Instant
7	7	4	Audible Instant
8	8	3	Audible Priority

Table 5 overleaf provides a description of the different zone types that may be programmed into these locations i.e. a value of 3 programmed into location 5 would cause zone 5 to be an audible priority zone.

**Table 5: Programmable Zone Types**

<b>Value</b>	<b>Zone Type</b>
0	<b>DISABLED</b> The zone will be disabled. Violation of a disabled zone is ignored.
1	<b>ENTRY/EXIT</b> Violation of an Entry/Exit zone is ignored during the exit delay period of the arming procedure. Violating an Entry/Exit zone when armed initiates the entry delay. The entry delay programmed into location 20 and the exit delay programmed into location 18 will be used. Failure to exit through an Entry/Exit zone after arming will enable the stay mode. If a valid user code is not entered before the entry delay period expires, an alarm condition will be registered. The behaviour of this zone type during the exit delay period is affected by the value programmed into location 9.
2	<b>FOLLOWER</b> A Violation of a Follower zone will be ignored during the <i>Entry/Exit Delay period</i> (this allows the user to enter/exit via the Follower zone). A Follower zone will behave as an Instant zone if the panel is armed and an Entry/Exit zone is not violated first. The behaviour of this zone type is affected by the value programmed into location 9.
3	<b>AUDIBLE PRIORITY/PANIC</b> Regardless of whether the panel is armed or not, a violation of an Audible Priority zone will cause the control panel to register an alarm condition and sound the siren.
4	<b>AUDIBLE INSTANT</b> If the panel is armed, the violation of an Instant zone will cause the control panel to immediately register an alarm condition. The behaviour of the siren will depend upon the value programmed into location 15. While the panel is unarmed, a violation of an Instant zone is ignored.
5	<b>ARM/DISARM</b> A violation of an Arm/Disarm zone will cause the panel to arm or disarm. To use this facility, connect a momentary key-switch or non-latching remote control unit to this zone. The end-of-line resistor will still be required.
6	<b>SILENT PRIORITY</b> Regardless of whether the panel is armed or not, a violation of a Silent Priority zone will not cause the siren to sound but will report the appropriate code programmed into the relevant program locations to the central station.
7	<b>SILENT INSTANT</b> If the panel is armed, the violation of a Silent zone will cause the control panel to immediately register an alarm condition. The siren will not sound. While the panel is unarmed, the violation of a Silent Instant zone is ignored. This zone is not affected by the value programmed into location 15.
8	<b>SECONDARY ENTRY/EXIT</b> The Secondary Entry Delay (see location 10) will be used when this zone is violated while the panel is armed. When entering the premises, and if a Secondary Entry/Exit zone is violated after a Primary Entry/Exit has been violated the panel will continue to countdown the Primary Entry Delay.
10	<b>FIRE ZONE</b> Violation of a Fire zone will cause the siren to sound regardless of whether the panel is armed or not. The siren will sound intermittently (one second on, one second off). A programmable output programmed as a fire detector power output (see location 37) will also be activated.
12	<b>PUSH TO ARM</b> If the value in location 18 is 15, once the exit delay has commenced, a violation of the Push to Arm zone will immediately arm the panel.



<b>LOCATION 9</b>	<b>Entry/Exit Options</b>
-------------------	---------------------------

Value	Entry/Exit Zones Must be Clear	Follower Zones Must be Clear	Entry/Exit Delay Enabled
0			
1			
2			
3			
4			
5			
6			
7			
8	●	●	✓
9 Default	✓	●	✓
10	●	✓	✓
11	✓	✓	✓
12	●	●	✓
13	✓	●	✓
14	●	✓	✓
15	✓	✓	✓

Instant Arm  
All zones must be clear

- ✓ Enabled
- Disabled

If the Entry/Exit delay is enabled, the panel can be programmed to allow arming with violated Follower and/ or Entry/Exit zones.

**NOTE:**

For all values programmed into location 9, the panel will only arm if the READY indicator is lit.

<b>LOCATION 10</b>	<b>Secondary Entry Delay</b>
--------------------	------------------------------

Value	Delay
0	0.25 seconds
1	10 seconds
2	20 seconds
3	30 seconds
4	45 seconds
5	1 minute (Default)
6	2 minutes
7	3 minutes

Value	Delay
8	4 minutes
9	5 minutes
10	10 minutes
11	15 minutes
12	18 minutes
13	21 minutes
14	24 minutes
15	27 minutes

The secondary entry delay applies to the secondary Entry/Exit zone. If a primary entry zone is violated, the primary entry delay is activated. If a subsequent violation of a secondary Entry/Exit zone occurs, the panel will continue to count down the primary delay. If a valid user code is not entered during this period, an alarm condition will occur.

<b>LOCATION 11</b>	<b>Tamper per Zone Enabled</b>
--------------------	--------------------------------

Value	Action
0 Default	Disabled
1	Enabled

See Section 3: End-of-Line Resistors/ Tamper per Zone for the correct use of tamper per zone.

<b>LOCATION 12</b>	<b>Arming Options</b>
--------------------	-----------------------

Value	Quick Arm	Entry/Exit Delay with Arm Zone	Forced Arming	Engineer Reset
0	●	●	●	●
1 Default	✓	●	●	●
2	●	✓	●	●
3	✓	✓	●	●
4	●	●	✓	●
5	✓	●	✓	●
6	●	✓	✓	●
7	✓	✓	✓	●
8	●	●	●	✓
9	✓	●	●	✓
10	●	✓	●	✓
11	✓	✓	●	✓
12	●	●	✓	✓
13	✓	●	✓	✓
14	●	✓	✓	✓
15	✓	✓	✓	✓

- ✓ Enabled
- Disabled

The quick arm option allows the user to arm the panel by holding down the **[1]** key until the keypad beeps. Using the quick arm key initiates an arming cycle as if a valid user code has been entered. User code 1 will be reported if the quick arm key is used.

The key-switch exit delay option enables or disables entry/ exit delays with key-switch arming. See Section 5 in the User Manual for information pertaining to key-switch arming.

Forced arming allows the panel to arm with violated zones e.g. an open window. Once the panel arms, a violated zone will bypass automatically. If a zone which has been automatically bypassed clears while the panel is armed, the zone will become active i.e. the window is pushed closed. Opening the window again will cause an alarm condition to be registered.

The Engineer reset function determines whether the panel can be armed after an alarm condition has been registered. This can be used to force the customer to have the system inspected in the event of an alarm condition.

- If the function is enabled:
  - If an alarm condition occurs and a valid user code is entered, thereby disarming the system, a trouble condition will be indicated. Upon entering the Trouble mode (hold down **[7]**), the indicator for zone 8 is on indicating that the installers code must be entered to clear this condition before re-arming. To clear the engineer reset simply enter the program mode by entering a valid **[INSTALLER CODE]** followed by **[\*]** followed by **[#]** to exit the program mode. The panel can now be armed.
- If the function is disabled:
  - The panel can be rearmed normally after an alarm condition has been registered. No trouble condition will be indicated.

<b>LOCATION 13</b>	<b>Stay Arm Options</b>
--------------------	-------------------------

Value	Action
0 Default	The Alarm Panel will automatically arm in the stay mode if the user arms and does not use the Entry/Exit zone (i.e. violation of an Entry/Exit zone).
1	The Alarm Panel will arm in the away mode even if no violation of an Entry/Exit zone occurs. The stay mode quick arm key (holding down <b>[5]</b> ) is also disabled.
2	The Alarm Panel will arm in the away mode even if no violation of an Entry/Exit zone occurs, however the stay mode quick arm key remains active.

The stay mode allows the user access to certain pre-programmed "stay" zones while the panel is armed. Zones that are programmed as stay zones (See Section 12 in the User Manual) will automatically be bypassed when the panel is armed into the stay mode. The **[5]** key will arm the panel in stay mode with no exit delay.

<b>LOCATION 14</b>	<b>Silent Keypad Panic Options</b>
--------------------	------------------------------------

Value	Action
0 Default	Disabled (audible panic)
1	Enabled (silent panic)

The value programmed into this location only affects the keypad panic.

<b>LOCATION 15</b>	<b>Silent Alarm Options</b>
--------------------	-----------------------------

Value	Action
0 Default	Disabled (audible alarm)
1	Enabled (silent alarm)

If a zone is programmed as a Silent Instant zone, an alarm condition as a result of a violation of this zone would be silent regardless of the value programmed into this location.

<b>LOCATION 16</b>	<b>Siren Toot on Arm &amp; Disarm</b>
--------------------	---------------------------------------

Value	Siren Toot on Arm	Siren Toot on Disarm
0 Default	●	●
1	✓	●
2	●	✓
3	✓	✓

- ✓ Enabled
- Disabled

This option allows the user to confirm that arming has occurred. The siren will give a short beep after successful arming, and two short beeps after disarming. This is recommended if a remote control or external key-switch is used.

**NOTE:**

The siren will *not* beep if the panel is stay armed into or disarmed from the stay mode.

<b>LOCATION 17</b>	<b>Siren Time Out Period</b>
--------------------	------------------------------

Value	Delay
0	0.25 seconds
1	10 seconds
2	20 seconds
3	30 seconds
4	45 seconds
5	1 minute
6	2 minutes (Default)
7	3 minutes

Value	Delay
8	4 minutes
9	5 minutes
10	10 minutes
11	15 minutes
12	18 minutes
13	21 minutes
14	21 minutes
15	21 minutes

The siren time out period is the period of time for which the siren will sound after an alarm condition is registered. Select the appropriate time-out period from the table above.

<b>LOCATION 18</b>	<b>Exit Delay Period</b>
--------------------	--------------------------

Value	Delay
0	0.25 seconds
1	10 seconds
2	20 seconds
3	30 seconds (Default)
4	45 seconds
5	1 minute
6	2 minutes
7	3 minutes

Value	Delay
8	4 minutes
9	5 minutes
10	10 minutes
11	15 minutes
12	18 minutes
13	21 minutes
14	21 minutes
15	21 minutes

This is the period of time allowed for exiting before the panel arms. The exit delay begins after entry of a valid user code. During this period, it is possible to violate Entry/Exit and Follower zones without causing an alarm condition. Select the appropriate exit delay period from the table above.

<b>LOCATION 19</b>	<b>AC Fail and Restore Time</b>
--------------------	---------------------------------

Value	Delay
0	1 minute
1	2 minutes (Default)
2	3 minutes
3	4 minutes
4	5 minutes
5	6 minutes
6	7 minutes
7	8 minutes

Value	Delay
8	9 minutes
9	10 minutes
10	11 minutes
11	12 minutes
12	13 minutes
13	14 minutes
14	15 minutes
15	16 minutes

If the AC power should fail, the panel will wait for this period of time before reporting the mains failure to the base station or logging the event to the event log. If the AC power is restored after the time out period has ended the same time out period will apply before the restoral event is reported and logged.

If the AC power is restored during the delay period neither the power failure, nor the power restoral will be reported or logged to the event log. This delay eliminates unnecessary reporting if the AC power to the panel is accidentally removed for a short period (provided the backup battery is in good condition, short AC power failures will not affect the functioning of the alarm system).

Select the appropriate value from the table above.

<b>LOCATION 20</b>	<b>Primary Entry Delay</b>
--------------------	----------------------------

Value	Delay
0	0.25 seconds
1	10 seconds
2	20 seconds
3	30 seconds (Default)
4	45 seconds
5	1 minute
6	2 minutes
7	3 minutes

Value	Delay
8	4 minutes
9	5 minutes
10	10 minutes
11	15 minutes
12	18 minutes
13	21 minutes
14	21 minutes
15	21 minutes

This is the period of time allowed to enter and disarm the panel before an alarm condition is registered. The entry delay begins after the violation of a primary Entry/Exit zone. During this period, it is permissible to violate Follower zones without causing an alarm condition provided that an Entry/Exit zone was violated first. If a Follower zone is violated without a prior Entry/Exit zone violation, it will be treated as an Instant zone. If an Instant zone is violated during this period, the alarm condition will immediately be registered. Select the appropriate value for the primary entry delay from the table above.

<b>LOCATION 21</b>	<b>Hardware Reset Switch Enable/Disable</b>
--------------------	---

**WARNING:**

Make certain that the new installer code has been correctly entered before disabling the reset switch.

Value	Action
10	Disable
15 Default	Enable

For the correct operation of this switch, refer to Section 8: Hardware Reset Switch.

<b>LOCATIONS 22-41</b>	<b>Programmable Output Controls</b>
------------------------	-------------------------------------

**SEE: LOCATIONS 158 - 170 for Additional Programmable Outputs**

These locations control the functioning of the 5 onboard programmable outputs. If a smoke detector, strobe light (or any other device requiring power) is connected to a programmable output, a relay board must be used to provide the high current. Please refer to the Section 5. Programmable Outputs.

Multiple events may be programmed to a single output. The output may be programmed to function as follows:

- Output pulsed for two seconds.
- Output may be latched high.
- Output may be latched low.

**Table 6: Output Options**

<b>Programmable Output</b>	<b>Program Value</b>		
	<b>Pulsed</b>	<b>Set Port High</b>	<b>Set Port Low</b>
Output 1	1	6	11
Output 2	2	7	12
Output 3	3	8	13
Output 4	4	9	14
Output 5	5	10	15

- The strobe and fire-detect outputs may only be programmed with [0] to [5] i.e. a pulsed output.
- The second phone number dialled output can only be programmed with values [1] - [5] ([0] will disable the output).

**Table 7: Output Options Default Values**

<b>Loc.</b>	<b>Event</b>	<b>Value</b>	<b>Default Action</b>
22	Alarm	2	Pulse prog. O/P 2
23	Audible priority	1	Pulse prog. O/P 1
24	Low battery	0	Disabled
25	Auto test	0	Disabled
26	Duress	1	Pulse prog. O/P 1
27	AC fail	0	Disabled
28	Close	8	Set prog. O/P 3 High
29	Open	13	Set prog. O/P 3 Low
30	AC restore	0	Disabled
31	Cancel	0	Disabled
32	Fire	0	Disabled
33	Medical	0	Disabled
34	Strobe	0	Disabled
35	Tamper	0	Disabled
36	Silent priority	1	Pulse prog. O/P 1
37	Fire detector power	0	Disabled
38	Chime	0	Disabled
39	Communication fail	0	Disabled
40	Phone No. 2 dialed	0	Disabled
41	D/L complete	0	Disabled

**Programming Example**

Program output No. 2 to report open and close, with close HIGH and open LOW:

It will be noted from Table 7 that output No. 2 is already assigned as the alarm output. This condition first needs to be disabled from output 2 before a new condition may be assigned otherwise CLOSE, OPEN and ALARM will all be programmed to Programmable Output 2. To do this a **[0]** should be programmed into location 22.

The location for a close instruction is location 28. From Table 6 it will be noted that a value of **[7]** programmed into this location will cause output 2 to go high. This output will remain high until the appropriately programmed value gives the instruction for this output to be set low. It will be noted that location 29 corresponds to an open condition. From Table 6 it will be noted that a value of **[12]** will drive output 2 low. Therefore, if a value of **[12]** is programmed into location 29 output 2 will be set low on an open condition.

If an output is programmed as a strobe output, the output will follow the sequence illustrated below.

**Figure 5: Strobe Output Sequence**

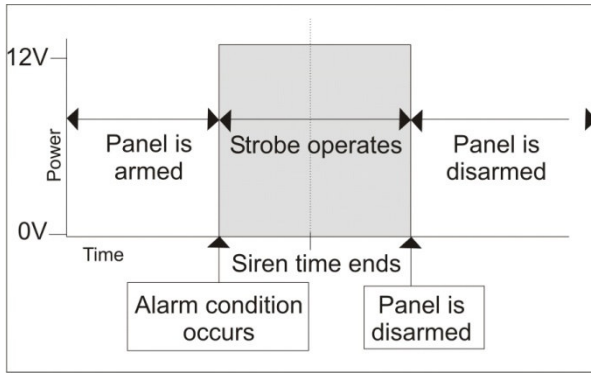

Similarly, a fire detect output follows the sequence illustrated overleaf.

**Figure 6: Fire Detect Output Sequence**

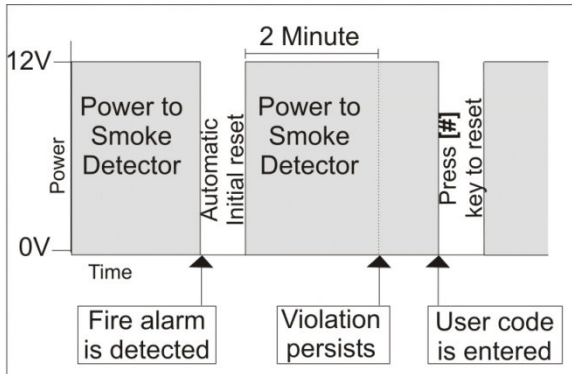

**NOTE:**

Since multiple conditions may be programmed to a single output, it is essential to ensure that no unwanted conditions are assigned to the same output.

<b>LOCATION 42</b>	<b>Phone Number Options/Dialling Options</b>
--------------------	--

Provision is made for the panel to dial different phone numbers (locations 48-63 for primary number and 64-79 for the secondary number). The panel can be programmed to report to these phone numbers as follows:

- Reporting codes can be programmed to report to a single central station (single reporting).
- Report independently to 2 central stations (dual reporting).
- The primary and secondary numbers may be joined to provide for a single number up to 32 digits.
- The numbers can be dialled using either tone or pulse dialling.



Enter the appropriate value from the following to setup the required phone number options.

Value	Join	Dial Mode
0	No	Pulse - single reporting
<b>Reporting:</b>		
➤ Pulse dial Primary and Secondary Telephone Numbers until communication is successful or for the number of attempts programmed into location 151.		

Value	Join	Dial Mode
1 Default	No	Tone - single reporting
<b>Reporting:</b>		
➤ As for value 0 but with tone dialing.		

Value	Join	Dial Mode
2	No	Pulse - dual reporting
<b>Reporting:</b>		
➤ Pulse dial Primary and Secondary Telephone Numbers until there has been a successful communication to both numbers or for the number of attempts programmed into location 151.		

Value	Join	Dial Mode
3	No	Tone - dual reporting
<b>Reporting:</b>		
➤ As for value 2 but with tone dialing instead of pulse dialing.		

Value	Join	Dial Mode
4	Yes	Pulse
<b>Reporting:</b>		
➤ Both telephone numbers would be dialed as a single number, this allows for the creation of a number longer than 16 digits.		
➤ All data will be communicated to this single number.		

Value	Join	Dial Mode
5	Yes	Tone
<b>Reporting:</b>		
➤ As for value 4 but with tone dialing instead of pulse dialing.		

➤ If single base reporting is selected, program the following locations:

- Locations 43-46 : Primary Account Code
- Location 47 : Primary Communicator Code
- Locations 48-63 : Primary Phone Number
- Locations 64-79 : Secondary phone Number

➤ If dual reporting is selected, program the following locations:

- Locations 43-46 : Primary Account Number
- Location 47 : Primary Communicator Format
- Locations 48-63 : Primary Phone Number
- Locations 64-79 : Secondary phone Number
- Locations 152-155 : Secondary Account Code
- Location 156 : Secondary Communicator Format

- If both phone numbers are to use the same communicator format and account codes then locations 43 - 47 must be programmed with the same values as locations 152-156.

<b>LOCATIONS 43-46</b>	<b>Primary Communicator Account Code</b>
------------------------	--

The four-digit account code for the telephone communicator is programmed into these locations. The panel is identified at the receiver by this account number.

- The account code *must* be four digits long. Any account number shorter than four digits *must* be preceded with "10"s.
- When programming locations 43-46 a **[0]** *must be entered* as a **[10]**.
- Sescoa Superfast format does not support account codes higher than 3374.
- The account code is not converted to hexadecimal by the panel when Sescoa Superfast is used.

The following table provides the conversion between the hexadecimal value and the value programmed into a particular location.

<b>Numerical Value</b>	1	2	3	4	5	6	7	8	9	10	11	12	13	14	15
<b>Hexadecimal Value</b>	1	2	3	4	5	6	7	8	9	A	B	C	D	E	F

Example: The desired account code is 14 (i.e. 0014)

1. Enter **[10]** into location 43.
2. Enter **[10]** into location 44.
3. Enter **[1]** into location 45.
4. Enter **[4]** into location 46.

<b>LOCATION 47</b>	<b>Primary Communicator Format</b>
--------------------	------------------------------------

Value	Action	Description
0 Default	Sescoa Superfast	1.8kHz TX, 2.3kHz HS
1	Ademco Express	Dual Tone Hs, DTMF
2	FBI 4 x 2 (No Parity)	1.8kHz TX, 2.3kHz HS, 20PPS
3	FBI 4 x 2 (Parity)	1.8kHz TX, 2.3kHz HS, 40PPS
4	Sescoa/Franklin Fast	1.8kHz TX, 2.3kHz HS, 20PPS
6	Contact-ID	Dual Tone HS, DTMF
7	Domestic Reporting	1.8kHz TX, Blind, 20PPS
12	Silent Knight 4 x 2 Fast	1.9kHz TX, 1.4kHz, 20PPS

TX = Transmit  
 HS = Handshake  
 PPS = Pulses per Second

The value entered into location 47 selects the format to be used for primary communication to the base station receiver or other device. Select from the table above the value appropriate to the required format. During communication, the green LED on the communicator PCB will come on. If programmed accordingly (see location 149), the keypad will beep once the panel has received a handshake from the base station. This indicates a successful transmission of data.

**NOTE ON DUAL REPORTING**

If dual reporting is enabled both base stations will receive the codes programmed into locations 80 - 133. Codes that are disabled are disabled to both communicator formats.

## NOTES ON CONTACT ID

If the panel has been programmed to use the Contact ID reporting format (i.e. location 47=6) it is *not* necessary to program the reporting codes. All codes will be reported by default. Table 8 contains a list of standard (default) Contact ID reporting codes. Under certain conditions, it may be necessary to change or disable certain codes. If a particular reporting code is not required, program a **[0]** (not "10") into the relevant locations.

Any event that relates to a specific zone, or to a specific user, will have the relevant zone/user number attached to the end of the Contact ID reporting code.

If dual reporting is enabled and the Contact ID reporting format is required, both the primary and secondary communicator formats need to be programmed as Contact ID. It is not possible to use Contact ID in conjunction with a second format e.g. Domestic Reporting, as the second format will transmit all codes as FF or F.

It is common not to report stay arming, away arming, and disarming for domestic alarms. To disable the reporting of these functions, program the following locations:

Arming or Closing code	Location 108 = 0
Disarming or Open code	Location 109 = 0
Home or Stay arming	Location 110 = 0

**Table 8: Standard Contact ID Reporting Codes**

Description	Codes	Description	Codes
Close by user	3401	Zone bypass	1570
Close by auto arm	3403	Zone shutdown	1573
Close by download	3407	Zone restoral	3130
Close with key-switch	3409	Tamper by zone	1137
Open by user	1401	Keypad tamper	1137
Open by download	1407	Keypad lockout	1137
Open with key-switch	1409	Panic zone	1120
Cancel	1406	Panic	1120
Burglary violation	1130	Keypad panic	1120
Perimeter violation	1131	AC fail	1301
Interior violation	1132	AC restoral	3301
24 Hour (Safe) violation	1133	Low battery	1302
Entry/exit violation	1134	Test report	1602
Day/night violation	1135	Keypad fire	1110
Outdoor violation	1136	Fire	1110
Tamper violation	1137	Duress	1121
Near alarm violation	1138	Keypad medical	1100
Box tamper	1144		

The generic Contact ID reporting code for an alarm caused by a zone violation is 1130, corresponding to a "BURGLARY" description. If you wish particular zone violations to be reported with a description other than BURGLARY an option may be chosen from Table 9 overleaf. The **first digit** of the reporting code relevant to that zone must be changed to the value as indicated in the table.

**Table 9: Alarm Reporting Codes**

<b>Value</b>	<b>Description</b>	<b>Reported As</b>
10	Burglary	1130
1	Perimeter	1131
2	Interior	1132
3	24 Hour (Safe)	1133
4	Entry/Exit	1134
5	Day/night	1135
6	Outdoor	1136
7	Tamper	1137
8	Near alarm	1138

**EXAMPLE**

Assuming for a given installation it is required to differentiate between entry/exit, interior and general burglary zones, and assuming that zone 1 is a front door (Entry/Exit zone), zone 2 is an interior PIR (Interior zone) and zone 3 is a general burglary zone.

Program the following locations

1. Location 86 (Zone 1) = 4 (Code 1134 = ENTRY/EXIT)
2. Location 88 (Zone 2) = 2 (Code 1132 = INTERIOR)
3. Location 90 (Zone 3) = 10 (Code 1130 = BURGLARY)

**NOTES ON DOMESTIC REPORTING:**

If dual reporting is enabled then domestic reporting will dial both phone numbers as programmed into locations 48-63 and 64-79. The data to be reported will be transmitted 3 times immediately after the phone number is dialed. This format provides for a simple form of easily identifiable remote alarm which may be reported to an office, mobile phone etc.

When using Domestic Reporting the number will be dialled and the data will be transmitted the number of times as programmed into the number of dial attempts (location 151).

**NOTES ON PROGRAMMING TELEPHONE NUMBERS:**

- To dial a "0" program a **[10]** into the location.
- To dial a "\*" program an **[11]** into the location.
- To dial a "#" program a **[12]** into the location.
- To create a 12 second pause in the number program a **[14]** into the location.
- To create a 4 second pause in the number program a **[15]** into the location.
- To terminate a telephone number, program a **[0]** (not 10) into the location immediately following the last digit of the telephone number.

<b>LOCATIONS 48-63</b>	<b>Primary Telephone Number</b>
------------------------	---------------------------------

<b>Loc. No.</b>	48	49	50	51	52	53	54	55	56	57	58	59	60	61	62	63

These locations contain the primary telephone number, which may be up to sixteen digits long. A four-second delay can be programmed at any point by entering a value of **[15]** in the respective location.

**EXAMPLE:**

Assuming a phone number consisting of an area code 031, a 4 second pause and a phone number of 705 1373

Location	Value Programmed	
48	10	- 1st digit of area code
49	3	- 2nd digit of area code
50	1	- 3rd digit of area code
51	15	- 4 second delay
52	7	- 1st digit of phone number
53	10	- 2nd digit of phone number
54	5	- 3rd digit of phone number
55	1	- 4th digit of phone number
56	3	- 5th digit of phone number
57	7	- 6th digit of phone number
58	3	- 7th digit of phone number
59	0	- terminate number

<b>LOCATIONS 64-79</b>	<b>Secondary Telephone Number</b>
------------------------	-----------------------------------

Loc. No.	64	65	66	67	68	69	70	71	72	73	74	75	76	77	78	79

These locations contain the secondary telephone number that may be up to sixteen digits long. The same procedures apply as for the Primary Telephone Number.

**Communicator Reporting Codes (Locations 80-133)**

With the exception of Contact ID and SESCOA Superfast, all other communications formats are 4 x 2 reporting formats i.e. a 4-digit account code will be reported with a 2 digit reporting code. It will be noted that some reporting functions require that both digits of the reporting code be programmed while others only require a single digit to be programmed. Reporting codes with only one digit will have the second digit added automatically by the panel. An explanation is provided under each reporting code. It is however important to note that wherever space is provided for the programming of 2 reporting digits i.e. Locations 86 and 87 for zone 1 reporting code BOTH DIGITS MUST BE PROGRAMMED.

**NOTE:**

- > To disable any of the reporting codes program a **[0]** into the locations for both digit 1 and digit 2.
- > All reporting codes that require a "0" to be reported must be programmed as a **[10]** i.e. An "A" will be reported in the place of the "0" as per the hexadecimal values below.

<b>Numerical Value</b>	1	2	3	4	5	6	7	8	9	10	11	12	13	14	15
<b>Hexadecimal Value</b>	1	2	3	4	5	6	7	8	9	A	B	C	D	E	F

<b>LOCATIONS 80-81</b>	<b>Duress Reporting Code</b>
------------------------	------------------------------

This code will be reported if the panel is disarming using the duress code (User 15 is the duress code – see the User Manual).

<b>LOCATIONS 82-83</b>	<b>Keypad Panic Reporting Code</b>
------------------------	------------------------------------

This code will be reported if the panic button [P] on the keypad is pressed.

<b>LOCATIONS 84-85</b>	<b>Keypad Tamper Reporting Code</b>
------------------------	-------------------------------------

The keypad tamper code will be reported if multiple attempts are made to disarm the panel using the wrong user code. The code will be reported after 16 incorrect keystrokes i.e. four incorrect user codes.

<b>LOCATIONS 86-101</b>	<b>Zone Reporting Codes</b>
-------------------------	-----------------------------

<b>Locations</b>	<b>Reporting Code</b>
86-87	Zone 1
88-89	Zone 2
90-91	Zone 3
92-93	Zone 4
94-95	Zone 5
96-97	Zone 6
98-99	Zone 7
100-101	Zone 8

Zone reporting codes will be reported if a violation of a zone causes an alarm condition. Various conditions will apply as to when an alarm condition will be registered. These conditions are determined by the zone characteristics as programmed into locations 1 to 8.

<b>LOCATIONS 102-103</b>	<b>AC Fail Reporting Code</b>
--------------------------	-------------------------------

The AC fail will only be reported if the AC power is lost for a period longer than the delay programmed into location 19.

<b>LOCATIONS 104-105</b>	<b>AC Restoral Reporting Code</b>
--------------------------	-----------------------------------

The AC restoral code will be reported if the AC power was lost for a period longer than the delay programmed into location 19 and only after the AC power has been restored for the same period of time.

<b>LOCATIONS 106-107</b>	<b>Siren Tamper Reporting Code</b>
--------------------------	------------------------------------

The siren tamper condition will be reported if the siren wire is open circuit or the fuse has blown.

<b>LOCATION 108</b>	<b>Close &amp; Away Reporting Code</b>
---------------------	--

The close code will be reported when the system is armed in the AWAY mode indicated by lit ARMED and AWAY LED's on the keypad.

**NOTE:**

The close code will not be reported if the system is armed in the STAY mode. The digit programmed into this location is the first digit of the reporting code. The second digit will automatically be added and will be the number which corresponds to the user code used to arm the system (See User Manual).

**EXAMPLE:**

If a close code of C (12) is programmed and the master user code is used to arm the system the 2 digit

reporting code would be C1 indicating a close by user 1.

**NOTE:**

If the system is armed using the quick arm "AWAY" key, the system will report a close by user 1.  
If the system is armed by means of a key or remote using an arm/disarm zone the system will report a close by user 13.

<b>LOCATION 109</b>	<b>Open Reporting Code</b>
---------------------	----------------------------

The open code will be reported when the system is disarmed.

**NOTE:**

The open code will not be reported if the system was armed in the stay mode and the stay arming reporting code (location 110) is 0 i.e. disabled.

The digit programmed into this location is the first digit of the reporting code. The second digit will automatically be added and will be the number which corresponds to the user code used to disarm the system (See User Manual).

**EXAMPLE:**

If an open code of B (11) is programmed and the master user code is used to disarm the system, the 2 digit reporting code would be B1 indicating an open by user 1.

**NOTE:**

If the system is disarmed by means of a key or remote using an arm/disarm zone the system will report open by user 13.

<b>LOCATION 110</b>	<b>Close &amp; Stay Reporting Code</b>
---------------------	--

The stay code will be reported when the system is armed in the stay mode indicated by a lit ARMED but off AWAY LED on the keypad. The digit programmed into this location is the first digit of the reporting code. The second digit will automatically be added and will be the number which corresponds to the user code used to arm the system (See User Manual). See the EXAMPLE and NOTE for location 108.

<b>LOCATIONS 111-112</b>	<b>Auto Test Reporting Code</b>
--------------------------	---------------------------------

This code is the test reporting code and will be reported at regular intervals as programmed into location 147. Reporting of this code is recommended as it provides verification that the system is functioning correctly.

<b>LOCATIONS 113-114</b>	<b>Keypad Fire Reporting Code</b>
--------------------------	-----------------------------------

This code will be reported if the fire button **[F]** on the keypad is pressed until the keypad beeps (approximately 1 second).

<b>LOCATIONS 115-116</b>	<b>Keypad Medical Reporting Code</b>
--------------------------	--------------------------------------

This code will be reported if the medical button **[M]** on the keypad is pressed until the keypad beeps repeatedly (approximately 1 second).

<b>LOCATION 117</b>	<b>Bypassed Zone Reporting Code</b>
---------------------	-------------------------------------

A zone bypass code will be reported if the panel is armed with a bypassed zone. The zone number will

be appended to this reporting code to provide the 2 digit reporting code.

<b>LOCATION 118</b>	<b>Tamper Zone Reporting Code</b>
---------------------	-----------------------------------

The zone tamper code will only be reported if the zone tamper function has been enabled, see location 11. The zone number will be appended to this reporting code to provide the 2 digit reporting code.

<b>LOCATION 119</b>	<b>Zone Shutdown Reporting Code</b>
---------------------	-------------------------------------

The zone shutdown code will be reported if the system is armed and a zone is automatically bypassed as a result of multiple violations of that zone while the panel is armed. The number of permissible violations is dependent on the value programmed into location 140. The zone number will be appended to this reporting code to provide the 2<sup>nd</sup> digit of the reporting code.

<b>LOCATION 120</b>	<b>Cancel Reporting Code</b>
---------------------	------------------------------

If the siren is sounding and the siren is cancelled by either a valid user code or key/remote, a cancel code will be reported. A silent alarm or silent panic will not cause the cancel code to be reported. The user number will be appended to this reporting code to provide the 2<sup>nd</sup> digit of the reporting code.

<b>LOCATION 121</b>	<b>Zone Restoral Reporting Code</b>
---------------------	-------------------------------------

If the panel is armed and a violation of a zone occurs followed by the zone returning to the normal (non-alarm) state, a zone violation followed by a zone restoral will be reported. The zone restoral code indicates that the zone has returned to the ready condition. The zone number will be appended to this reporting code to provide the 2<sup>nd</sup> digit of the reporting code.

<b>LOCATIONS 122-123</b>	<b>Download Complete Reporting Code</b>
--------------------------	---

This code will be sent once a successful download to a panel has been completed.

<b>LOCATIONS 124-125</b>	<b>TLM Fail Reporting Code</b>
--------------------------	--------------------------------

This code will be sent if telephone line monitoring is enabled and the line voltage drops below 9V for more than 30-60 seconds. A failure condition will be logged in the event log and if armed in the away mode the siren will sound.

**NOTE:**

A TLM failure indicates that the telephone line is either not functional or not present. This reporting code should only be used in conjunction with a radio linked to the dialler.

<b>LOCATIONS 126-127</b>	<b>TLM Restore Reporting Code</b>
--------------------------	-----------------------------------

This code will be sent once telephone line monitoring has been restored.

<b>LOCATIONS 128-129</b>	<b>Low Battery Reporting Code</b>
--------------------------	-----------------------------------

The low battery condition will be reported if the battery voltage drops below 10 volts. If the battery fuse blows then the battery will discharge and a low battery condition will be reported, even if the AC power is present.

<b>LOCATIONS 130-131</b>	<b>Low Battery Restoral Reporting Code</b>
--------------------------	--

This code will be sent once the battery voltage has been restored. The battery voltage has to rise to



above 11.9V for the panel to register a restoral.

<b>LOCATIONS 132-133</b>	<b>Box Tamper Reporting Code</b>
--------------------------	----------------------------------

The box tamper reporting code will be reported if there are open circuit box tamper contacts for more than 200ms.

<b>LOCATIONS 134-135</b>	<b>Reserved</b>
--------------------------	-----------------

<b>LOCATIONS 136-139</b>	<b>Installer ID Code (Default = 9999)</b>
--------------------------	---

The installer's ID code is used by the installer to enter the program mode. This may be changed by entering a new 4-digit code into these 4 locations.

Although not possible from the keypad, it is possible using the IDS PC download software to enter an installers ID code containing the hexadecimal digits A-F. If these digits are used as part of the installers ID, it will prevent access to programming mode from the keypad. In this case, program access can only be achieved by using the IDS PC download software.

<b>LOCATION 140</b>	<b>Swinger Shutdown Count Value (Default = 0)</b>
---------------------	---

Determines the number of times a zone may be violated during an arm cycle before it is automatically bypassed. The count will be twice the value entered. The maximum value of 15 may be entered, corresponding to 30 violations required to force the zone to bypass. Disable swinger shutdown by entering **[0]** in this location.

<b>LOCATION 141</b>	<b>Zone Loop Response</b>
---------------------	---------------------------

<b>Value</b>	<b>Action</b>	
0 Default	Response time	- 100ms
1	Response time	- 12ms
2	Response time	- 24ms
3	Response time	- 36ms
4	Response time	- 48ms
5	Response time	- 60ms
6	Response time	- 72ms
7	Response time	- 84ms
8	Response time	- 96ms
9	Response time	- 108ms
10	Response time	- 120ms
11	Response time	- 132ms
12	Response time	- 144ms
13	Response time	- 156ms
14	Response time	- 168ms
15	Response time	- 180ms

The zone loop response is the period of time for which the zone must be violated before a violation is registered. A value of **[0]** provides a loop response time of 100ms.

<b>LOCATION 142</b>	<b>Zone Trip Count (Default = 0)</b>
---------------------	--------------------------------------

This feature is to prevent false alarms while the panel is armed. If the panel is armed and a Follower zone is violated the number of times programmed into this location within the time period programmed into

location 143, then an alarm condition will be registered. Program a value from [0] to [15]. A [0] will disable the location. Please note that this only applies to Follower zones and Instant zones remain instant.

<b>LOCATION 143</b>	<b>Zone Trip Count Time Delay (Default = 0)</b>
---------------------	---

This time delay period applies to location 142. If the panel is armed and the number of violations programmed into location 142 occurs within this time delay, an alarm condition will register. Program a value from [0] to [15]. Multiply the value of the entry by 10 seconds to calculate the delay time.

<b>LOCATION 144</b>	<b>Programmable Trouble Display 1</b>
---------------------	---------------------------------------

Value	Display of TLM Fail	Display of Siren Tamper
0	●	●
1	✓	●
2	●	✓
3 Default	✓	✓

- ✓ Enabled
- Disabled

This location determines whether telephone line monitoring failure or siren tamper are displayed as trouble conditions. Should the display be disabled no trouble condition will be shown i.e. the power LED will not flash and no trouble condition shown when entering trouble-viewing mode. However, reporting codes, if programmed, will be reported to the base station.

<b>LOCATION 145</b>	<b>Programmable Trouble Display 2</b>
---------------------	---------------------------------------

Value	Display of Comms. Fail	Display of Keypad Tamper	Display of Eng. Reset
0	●	●	●
1	✓	●	●
2	●	✓	●
3	✓	✓	●
4	●	●	✓
5	✓	●	✓
6	●	✓	✓
7 Default	✓	✓	✓

- ✓ Enabled
- Disabled

This location determines whether Communication failure, keypad tamper, or engineers reset are displayed as trouble conditions. Should the display be disabled no trouble condition will be shown i.e. the power LED will not flash and no trouble condition shown when entering trouble-viewing mode. However, reporting codes, if programmed, will be reported to the base station.

**NOTE:**

- Low battery and AC fail trouble condition displays cannot be disabled.
- If Engineer reset is enabled (see location 12), but the trouble condition display is disabled, the panel will not show a trouble condition if an alarm condition has been registered but the system will not arm until an Installer code has been entered.

<b>LOCATION 146</b>	<b>Keypad Sleep Delay</b>
---------------------	---------------------------

Value	Delay
0	Disabled
1	16 seconds
2	32 seconds
3	48 seconds
4	64 seconds
5	80 seconds
6	96 seconds
7	112 seconds

Value	Delay
8 (Default)	128 seconds
9	144 seconds
10	160 seconds
11	176 seconds
12	192 seconds
13	208 seconds
14	224 seconds
15	240 seconds

This location programs the period of time that the keypad's backlighting will remain on without activity. **[0]** disables this function resulting in constantly lit keys. The location can have a value from **[0]** to **[15]**.

<b>LOCATION 147</b>	<b>Auto Test delay</b>
---------------------	------------------------

Value	Action
0 Default	Reports every 24 hours
1	Reports every 48 hours
6	Reports every 7 days i.e. once a week

The time period between auto test reports is programmed using this location. The time period is incremented in 24-hour increments with the shortest time period being 24 hours. The maximum value which may be programmed into this location is 15.

<b>LOCATION 148</b>	<b>Number of Rings Before Answer (Default = 15)</b>
---------------------	---

This location programs the number of rings before the panel picks up the telephone line and attempts to up/download. In the event that the panel picks up the phone and no valid download log on sequence is received by the panel, the call will be terminated by the panel after 40 seconds.

Note that the **default value of 15** (maximum permissible value) enables the fax defeat mode. If fax defeat is enabled and the phone rings 15 times the panel will answer the call, if however, the phone rings and the call is terminated within 3 rings the panel will within a 60-second window answer a second call on the first ring.

Fax defeat is a useful feature for downloading when a fax or answering machine is connected to the same phone line as the Alarm Panel. If enabled, dial the panel and hang up before 3 rings. Dial the panel again within 1 minute. The panel will pick up the call on the first ring thereby preventing the fax/ answering machine from answering the call before the Alarm Panel. A number lower than 15 programmed into this location disables the fax defeat mode.

<b>LOCATION 149</b>	<b>Keypad Buzzer Options</b>
---------------------	------------------------------

<b>Value</b>	<b>Action</b>
0	No beep
1	Beep on trouble
2 Default	Beep on communication
3	Beep on trouble, beep on communication

The keypad can be programmed to beep once to indicate successful communication of data to the base station, and intermittently (on/off) to provide and audible indication of a trouble condition. The beeping can be cancelled by pressing **[#1]**. For a list of trouble conditions and how to view them refer to the section headed "Trouble Conditions" in the User Manual. Enter the appropriate value from the above table.

<b>LOCATION 150</b>	<b>Hardware Enable Siren/TLM</b>
---------------------	----------------------------------

<b>Value</b>	<b>Telephone Line Monitoring</b>	<b>Siren Tamper Monitoring</b>	<b>Box Tamper Monitoring</b>
0 Default	●	●	●
1	✓	●	●
2	●	✓	●
3	✓	✓	●
4	●	●	✓
5	✓	●	✓
6	●	✓	✓
7	✓	✓	✓

- ✓ Enabled
- Disabled

This location allows the permanent enabling/ disabling of telephone line and siren tamper monitoring. For example, if the telephone line monitoring has been disabled, if the line voltage drops below 9V for more than 30-60 seconds, it will not be reported to the base station or to the panel as a trouble condition nor will it be recorded on the event log.

<b>LOCATION 151</b>	<b>Dial Attempts (Default = 4)</b>
---------------------	------------------------------------

Determines the maximum number of dial attempts the panel will make to contact the base station.

**NOTE:**

Entering **[0]** into this location will disable the dialler.

<b>LOCATIONS 152-155</b>	<b>Secondary Communicator Account Code</b>
--------------------------	--

This account code is used if the panel is communicating to two base stations and will be transmitted to the secondary phone number. See Locations 43 - 46 for information regarding the programming of these locations.

<b>LOCATION 156</b>	<b>Secondary Communicator Format (Default = 0)</b>
---------------------	--

This communicator format is used if the panel is communicating to two base stations and will be transmitted to the secondary phone number. See Location 47 and the subsequent notes for information regarding the programming of this location.

<b>LOCATION 157</b>	<b>Communication Delay (Default = 0)</b>
---------------------	--

If an event occurs that will be reported, the panel will wait for this period of time before transmitting the relevant reporting codes either by phone or radio outputs. If a valid user code is entered during the delay period, the reporting codes will not be transmitted. The event will still be recorded in the event log. The value of this location ranges from 0 to 75 seconds in 5 second increments. Program a value from **[0]** to **[15]**. Multiply the value of the entry by 5 seconds to calculate the delay time.

The communication of the following events will not be delayed under any circumstances:

- Duress
- Audible/ Silent Priority Zones
- Keypad Panic
- Keypad Medical
- Keypad Fire
- Zone Programmable Outputs (see Loc. 158 - 165)

<b>LOCATIONS 158-165</b>	<b>Programmable Output Controls - Zones</b>
--------------------------	---

**SEE LOCATIONS 22 - 44 and TABLE 6**

<b>Loc.</b>	<b>Event</b>	<b>Value</b>	<b>Default Action</b>
158	Zone 1 output	0	Disabled
159	Zone 2 output	0	Disabled
160	Zone 3 output	0	Disabled
161	Zone 4 output	0	Disabled
162	Zone 5 output	0	Disabled
163	Zone 6 output	0	Disabled
164	Zone 7 output	0	Disabled
165	Zone 8 output	0	Disabled

A programmable output will be activated when a zone is violated.

<b>LOCATION 166</b>	<b>Low Battery Restoral Prog. O/P (Default = 0)</b>
---------------------	---

This output will be triggered once the battery voltage has been restored i.e. the voltage risen to above 11.9V.

<b>LOCATION 167</b>	<b>TLM Fail Programmable Output (Default = 0)</b>
---------------------	---

This output will be triggered if telephone line monitoring is enabled, and the line voltage drops below 9V for more than 30-60 seconds.

<b>LOCATION 168</b>	<b>TLM Restore programmable Output (Default = 0)</b>
---------------------	--

This output will be triggered once telephone line monitoring has been restored to 9V for longer than 30-60 seconds.

<b>LOCATION 169</b>	<b>Siren Tamper Programmable Output (Default = 0)</b>
---------------------	---

The siren tamper output will be triggered if the siren wire is open circuit for more than 5 seconds or the fuse has blown.

<b>LOCATION 170</b>	<b>Box Tamper Programmable Output (Default = 0)</b>
---------------------	---

The box tamper output will be triggered if the panel box is opened.

### **Set System Time, Auto Test Time, Automatic Arm Time**

All time values must be entered as a 4-digit value in hours and minutes in a 24-hour format i.e. 1.00pm is entered as 1300.

To view and change values in these locations:

1. Enter programming mode by entering a valid **[INSTALLER CODE]** followed by **[\*]**.
2. Enter **[LOCATION NUMBER]** e.g. 800 followed by **[\*]**.
3. The value displayed by the LED's will be the hour value.
4. Press **[\*]** and the LED's will display the minutes value.

It is necessary to display the hours and minutes separately as it is not possible to display 4 digits on the keypad simultaneously.

<b>LOCATION 800</b>	<b>System Time (Default = 0000)</b>
---------------------	-------------------------------------

This location is used for setting the system clock time.

<b>LOCATION 801</b>	<b>Auto Test Time (Default = 0100)</b>
---------------------	--

This location is used for setting the time of day at which the auto test will be reported.

#### **EXAMPLE:**

If a value of 6 was programmed into location 147 and 1400 was programmed into location 801, the auto test would be sent every seven days at 2:00pm.

<b>LOCATION 802</b>	<b>Auto Arm Time (Default = 9999)</b>
---------------------	---------------------------------------

This location sets the time at which the panel will automatically arm every day (if enabled). The auto arm feature is disabled by entering an invalid time greater than 2400 e.g. 9999.

The table below indicates the trouble conditions. Hold down [7] to view the trouble status.

**Table 10: Trouble Conditions**

<b>Indicator</b>	<b>Trouble Condition</b>
2	Failure to communicate to monitoring company
3	Mains power failure
4	Low battery
5	Telephone line is cut or not present
6	The siren wire has been cut or the fuse has blown
7	Keypad has experienced a tamper
8	Installers code must be entered to clear an alarm condition

<b>LOC</b>	<b>Description</b>	<b>New Value</b>	<b>Default</b>	<b>Def. Data</b>	<b>Pg</b>
0	Reset to Factory Default		0 to Reset		15
1	Zone 1 Type		Entry/exit	1	15
2	Zone 2 Type		Follower	2	15
3	Zone 3 Type		Audible Instant	4	15
4	Zone 4 Type		Audible Instant	4	15
5	Zone 5 Type		Audible Instant	4	15
6	Zone 6 Type		Audible Instant	4	15
7	Zone 7 Type		Audible Instant	4	15
8	Zone 8 Type		Audible Priority	3	15
<b>System Options</b>					
9	Entry/Exit Options		See location	9	17
10	Secondary Entry Delay		1 Minute	5	17
11	Tamper per Zone Enable/Disable		Disabled	0	18
12	Arming Options		See location	1	18
13	Stay Arm Options		Stay Mode Enabled	0	19
14	Silent Keypad Panic Options		Silent Panic Disabled	0	19
15	Silent Alarm Options		Silent Alarm Disabled	0	19
16	Siren Toot on Arm/Disarm		No Toot	0	20
17	Siren Time Out Period		2 Minutes	6	20
18	Exit Delay Period		30 Seconds	3	20
19	AC Fail and Restore Time		2 Minutes	1	21
20	Primary Entry Delay		30 Seconds	3	21
21	Hardware Reset Switch Enable/Disable		Enabled	15	21
<b>Out-Put Options</b>					
22	Alarm Prog. O/P		Pulse Prog. O/P	2	22
23	Audible Priority Prog. O/P		Pulse Prog. O/P	1	22
24	Low Battery Prog. O/P		Disabled	0	22
25	Auto Test Prog. O/P		Disabled	0	22
26	Duress Prog. O/P		Pulse Prog. O/P	1	22
27	AC Fail Prog. O/P		Disabled	0	22
28	Close & Away Prog. O/P		Set Prog. O/P 3 High	8	22
29	Open Prog. O/P		Set Prog. O/P 3 Low	13	22
30	AC Restore Prog. O/P		Disabled	0	22
31	Cancel Prog O/P		Disabled	0	22
32	Fire Prog. O/P		Disabled	0	22
33	Medical Prog. O/P		Disabled	0	22
34	Strobe Prog. O/P		Disabled	0	22
35	Tamper Prog. O/P		Disabled	0	22
36	Silent Priority Prog. O/P		Pulse Prog OP 1	1	22
37	Fire Detect Power Prog. O/P		Disabled	0	22
38	Aux. Chime Prog. O/P		Disabled	0	22
39	Comms Fail Prog. O/P		Disabled	0	22
40	Phone Number 2 Prog. O/P		Disabled	0	22
41	D/L Complete		Disabled		22
<b>Primary Communication Options</b>					
42	Dialling Options		Tone	1	24
43	Primary Account Code Digit 1		Disabled	0	26



<b>LOC</b>	<b>Description</b>	<b>New Value</b>	<b>Default</b>	<b>Def. Data</b>	<b>Pg</b>
44	Primary Account Code Digit 2		Disabled	0	26
45	Primary Account Code Digit 3		Disabled	0	26
46	Primary Account Code Digit 4		Disabled	0	26
47	Primary Communicator Format		Sescoa Superfast	0	26
<b>Primary Phone Number</b>					
48	Phone No. 1 Digit 1		Disabled	0	28
49	Phone No. 1 Digit 2		Disabled	0	28
50	Phone No. 1 Digit 3		Disabled	0	28
51	Phone No. 1 Digit 4		Disabled	0	28
52	Phone No. 1 Digit 5		Disabled	0	28
53	Phone No. 1 Digit 6		Disabled	0	28
54	Phone No. 1 Digit 7		Disabled	0	28
55	Phone No. 1 Digit 8		Disabled	0	28
56	Phone No. 1 Digit 9		Disabled	0	28
57	Phone No. 1 Digit 10		Disabled	0	28
58	Phone No. 1 Digit 11		Disabled	0	28
59	Phone No. 1 Digit 12		Disabled	0	28
60	Phone No. 1 Digit 13		Disabled	0	28
61	Phone No. 1 Digit 14		Disabled	0	28
62	Phone No. 1 Digit 15		Disabled	0	28
63	Phone No. 1 Digit 16		Disabled	0	28
<b>Secondary Phone Number</b>					
64	Phone No. 2 Digit 1		Disabled	0	29
65	Phone No. 2 Digit 2		Disabled	0	29
66	Phone No. 2 Digit 3		Disabled	0	29
67	Phone No. 2 Digit 4		Disabled	0	29
68	Phone No. 2 Digit 5		Disabled	0	29
69	Phone No. 2 Digit 6		Disabled	0	29
70	Phone No. 2 Digit 7		Disabled	0	29
71	Phone No. 2 Digit 8		Disabled	0	29
72	Phone No. 2 Digit 9		Disabled	0	29
73	Phone No. 2 Digit 10		Disabled	0	29
74	Phone No. 2 Digit 11		Disabled	0	29
75	Phone No. 2 Digit 12		Disabled	0	29
76	Phone No. 2 Digit 13		Disabled	0	29
77	Phone No. 2 Digit 14		Disabled	0	29
78	Phone No. 2 Digit 15		Disabled	0	29
79	Phone No. 2 Digit 16		Disabled	0	29
<b>Reporting Codes</b>					
80	Duress Reporting Code Digit 1		Disabled	0	29
81	Duress Reporting Code Digit 2		Disabled	0	29
82	Keypad Panic Reporting Code Digit 1		Disabled	0	30
83	Keypad Panic Reporting Code Digit 2		Disabled	0	30
84	Keypad Tamper Reporting Code Digit 1		Disabled	0	30
85	Keypad Tamper Reporting Code Digit 2		Disabled	0	30
86	Zone 1 Alarm Reporting Code Digit 1		Disabled	0	30
87	Zone 1 Alarm Reporting Code Digit 2		Disabled	0	30
88	Zone 2 Alarm Reporting Code Digit 1		Disabled	0	30

<b>LOC</b>	<b>Description</b>	<b>New Value</b>	<b>Default</b>	<b>Def. Data</b>	<b>Pg</b>
89	Zone 2 Alarm Reporting Code Digit 2		Disabled	0	30
90	Zone 3 Alarm Reporting Code Digit 1		Disabled	0	30
91	Zone 3 Alarm Reporting Code Digit 2		Disabled	0	30
92	Zone 4 Alarm Reporting Code Digit 1		Disabled	0	30
93	Zone 4 Alarm Reporting Code Digit 2		Disabled	0	30
94	Zone 5 Alarm Reporting Code Digit 1		Disabled	0	30
95	Zone 5 Alarm Reporting Code Digit 2		Disabled	0	30
96	Zone 6 Alarm Reporting Code Digit 1		Disabled	0	30
97	Zone 6 Alarm Reporting Code Digit 2		Disabled	0	30
98	Zone 7 Alarm Reporting Code Digit 1		Disabled	0	30
99	Zone 7 Alarm Reporting Code Digit 2		Disabled	0	30
100	Zone 8 Alarm Reporting Code Digit 1		Disabled	0	30
101	Zone 8 Alarm Reporting Code Digit 2		Disabled	0	30
102	AC Fail Reporting Code Digit 1		Disabled	0	30
103	AC Fail Reporting Code Digit 2		Disabled	0	30
104	AC Restore Reporting Code Digit 1		Disabled	0	30
105	AC Restore Reporting Code Digit 2		Disabled	0	30
106	Siren Tamper Reporting Code Digit 1		Disabled	0	30
107	Siren Tamper Reporting Code Digit 2		Disabled	0	30
108	Close & Away Reporting Code		Disabled	0	33
109	Open Reporting Code		Disabled	0	31
110	Close & Stay Reporting Code		Disabled	0	31
111	Auto Test Reporting Code Digit 1		Disabled	0	31
112	Auto Test Reporting Code Digit 2		Disabled	0	31
113	Keypad Fire Reporting Code Digit 1		Disabled	0	31
114	Keypad Fire Reporting Code Digit 2		Disabled	0	31
115	Keypad Medical Reporting Code Digit 1		Disabled	0	31
116	Keypad Medical Reporting Code Digit 2		Disabled	0	31
117	Bypassed Zone Reporting Code		Disabled	0	31
118	Zone Tamper Reporting Code		Disabled	0	32
119	Zone Shutdown Reporting Code		Disabled	0	32
120	Cancel Reporting Code		Disabled	0	32
121	Zone Restoral Reporting Code		Disabled	0	32
122	Download Complete Reporting Code Digit 1		Disabled	0	32
123	Download Complete Reporting Code Digit 2		Disabled	0	32
124	TLM Fail Reporting Code Digit 1		Disabled	0	32
125	TLM Fail Reporting Code Digit 2		Disabled	0	32
126	TLM Restore Reporting Code Digit 1		Disabled	0	32
127	TLM Restore Reporting Code Digit 2		Disabled	0	32
128	Low Battery Reporting Code Digit 1		Disabled	0	32
129	Low Battery Reporting Code Digit 2		Disabled	0	32
130	Low Battery Restore Rep. Code Digit 1		Disabled	0	32
131	Low Battery Restore Rep. Code Digit 2		Disabled	0	32
132	Box Tamper Rep. Code Digit 1		Disabled	0	33
133	Box Tamper Rep. Code Digit 2		Disabled	0	33
134	Reserved				33
135	Reserved				33

<b>LOC</b>	<b>Description</b>	<b>New Value</b>	<b>Default</b>	<b>Def. Data</b>	<b>Pg</b>
136	Installers Code Digit 1			9	33
137	Installers Code Digit 2			9	33
138	Installers Code Digit 3			9	33
139	Installers Code Digit 4			9	33
140	Swinger Shutdown Count		Disabled	0	33
141	Zone Loop response		100ms	0	33
142	Zone Trip Count		Disabled	0	33
143	Zone Trip Count Time Delay		Disabled	0	34
144	Programmable Trouble Display 1		See location	3	34
145	Programmable Trouble Display 2		See location	7	34
146	Keypad Sleep Delay		128 Seconds	8	35
147	Auto Test Delay		Every 24 Hours	0	35
148	No. of Rings Before Answer		15 Rings	15	35
149	Keypad Buzzer Options		Beep on Communication	2	36
150	Hardware Enable: Siren / TLM		Disabled	0	36
151	Dial Attempts		Four	4	36
<b>Secondary Communicator Options</b>					
152	Secondary Account Code Digit 1		Disabled	0	36
153	Secondary Account Code Digit 2		Disabled	0	36
154	Secondary Account Code Digit 3		Disabled	0	36
155	Secondary Account Code Digit 4		Disabled	0	36
156	Secondary Communicator Format		Sescoa Superfast	0	37
157	Communication Delay		No delay	0	37
<b>Zone Programmable Out-puts</b>					
158	Zone 1 Prog. O/P		Disabled	0	37
159	Zone 2 Prog. O/P		Disabled	0	37
160	Zone 3 Prog. O/P		Disabled	0	37
161	Zone 4 Prog. O/P		Disabled	0	37
162	Zone 5 Prog. O/P		Disabled	0	37
163	Zone 6 Prog. O/P		Disabled	0	37
164	Zone 7 Prog. O/P		Disabled	0	37
165	Zone 8 Prog. O/P		Disabled	0	37
166	Low Battery Restoral Prog. O/P		Disabled	0	37
167	TLM Fail Prog. O/P		Disabled	0	37
168	TLM Restoral Prog. O/P		Disabled	0	37
169	Siren Tamper Prog. O/P		Disabled	0	38
170	Box Tamper Prog. O/P		Disabled	0	38
800	System Time		Disabled	0	38
801	Auto Test Time		1a.m.	0100	38
802	Automatic Arm Time		Disabled	9999	38

# Index

## A

AC Fail.....	12, 21, 23, 27, 30, 35
AC Restore.....	21, 23, 27, 30
Alarm Memory.....	47
Arm/Disarm Zone.....	see "Zone"
Audible Instant Zone.....	see "Zone"
Audible Priority Zone.....	see "Zone"
Auto Arm.....	7, 38
Time.....	38
Auto Test.....	23, 31, 38
Delay.....	35
Time.....	38
Auxiliary Power Outputs.....	7
Away Mode.....	19, 30, 32

## B

Base Station.....	7, 12, 21, 26, 34, 36, 37
Battery.....	7, 11, 12, 21, 23, 27, 32, 35, 37, 39
Fuse.....	11, 32
Binary.....	13, 14
Buzz.....	47
Bypass.....	18, 19, 27, 31, 32, 33, 47

## C

Chime.....	11, 23, 47
Communicator.....	7, 10, 11, 12, 29
Format.....	15, 26, 37
Primary Account Code.....	25, 26
Secondary Account Code.....	25, 27, 36
Contact ID.....	15, 27, 29

## D

Dial Attempts.....	18, 36
Dialler Progress.....	7, 12
Dialling	
Pulse.....	24, 25
Tone.....	25
Dialling Options.....	24
Domestic Reporting.....	26, 27, 28
Download.....	7, 12, 13, 27, 32, 33, 35
Download Code.....	13
Download Complete Reporting Code.....	32
DTMF.....	26
Dual Reporting.....	7, 24, 25, 26, 27, 28
Duress.....	23, 27, 29, 37, 47

## E

End-of-Line Resistors.....	7, 9, 16, 18
Engineer Reset.....	18, 19, 35
Entry	
Delay.....	16, 17, 21

Primary Delay.....	16, 17, 21
Secondary Delay.....	16, 17
Entry/ Exit Zone.....	see "Zone"
Event Log.....	7, 12, 21, 32, 36, 37
Exit Delay.....	10, 16, 17, 18, 19, 20

## F

Factory Default Values.....	11, 15
Fax Defeat Mode.....	35
Fire.....	16, 22, 23, 24, 27, 31, 37, 47
Fire Zone.....	see "Zone"
Follower Zone.....	see "Zone"
Forced Arming.....	18

## H

Hardware Reset Switch.....	11, 21, 22
Hexadecimal.....	26, 29, 33

## I

Installer Code.....	11, 14, 19, 21, 35, 38
---------------------	------------------------

## K

Keypad Sleep Delay.....	35
Key-switch.....	10, 16, 18, 20, 27

## L

Lightning.....	7, 10
Line Seizure Mode.....	10
Loop Response Time.....	7, 33

## M

Master User Code.....	15, 30, 31
Medical Alarm.....	23, 27, 31, 37, 47

## P

Panic.....	7, 9, 10, 11, 16, 19, 27, 30, 32, 37, 47
Phone Numbers.....	see "Telephone Numbers"
Power Failure.....	7, 12, 21, 39
Primary Communicator Format.....	see "Communicator"
Primary Entry Delay.....	see "Entry"
Programmable Outputs.....	10, 16, 22, 23, 37, 38
Programming Mode.....	14, 33, 38
Push to Arm Zone.....	see "Zone"

## Q

Quick Arm.....	18, 19, 31
----------------	------------

**R**

Relay Board.....	10, 22
------------------	--------

**S**

Secondary Communicator Format.....	see "Communicator"
Secondary Entry/Exit.....	see "Entry"
Sescoa Superfast.....	26, 29
Siren.....	7, 9, 11, 16, 20, 30, 32, 34, 36, 38, 39
Time Out Period.....	20
Stay Arm.....	19, 20, 27, 31, 47
Stay Mode.....	16, 19, 20, 30, 31
Stay Profile.....	47
Strobe.....	22, 23, 24
System Time.....	38
Swinger Shutdown.....	33

**T**

Tamper.....	7, 9, 11, 23, 27, 28, 30, 32, 33, 34, 36, 38, 39
Tamper per Zone.....	8, 9, 10, 18, 27
Telephone Numbers.....	25, 28
Primary.....	25, 28, 29
Secondary.....	25, 29
Trouble Condition.....	19, 34, 35, 36, 37, 39
Trouble Condition Display.....	35
Trouble Mode.....	19

**Z**

Zone Arm/Disarm.....	10, 16, 31
Audible Instant.....	15, 16
Audible Priority.....	15, 16, 23
Disable.....	16
Entry/Exit.....	10, 15, 16, 17, 18, 19, 20, 21, 27, 28
Fire.....	16
Follower.....	16, 17, 20, 21, 33, 34
Instant.....	16, 19, 21, 34
Panic.....	7, 9, 10, 11, 27
Primary Entry/Exit.....	16, 21
Push to Arm.....	16
Secondary Entry/Exit.....	16, 17
Silent Instant.....	16, 19
Silent Priority.....	16, 23, 37
Stay.....	19, 47
Trip Count.....	33
Trip Count Time Delay.....	34

## Quick Reference User Guide

Arm/Disarm	<b>[#] + [USER CODE]</b>
Quick Away Arm	Hold down <b>[1]</b> for 1 second
Quick Stay Arm	Hold down <b>[5]</b> for 1 second
Quick Stay Arm & Go	Hold down <b>[6]</b> for 1 second
Panic	Hold down <b>[P]</b> for 1 second
Fire	Hold down <b>[F]</b> for 1 second
Medical Emergency	Hold down <b>[M]</b> for 1 second
Alarm Memory	Hold down <b>[0]</b> for 1 second
Change Stay Profile	<b>[MODE] + [9] + [PROFILE NUMBER] + [*]</b>
Bypass a zone	<b>[*] + [ZONE NUMBER]</b>
Program chime zone	Hold down <b>[2]</b> for 1 second + <b>[ZONE NUMBER] + [*]</b>
Program stay zone	Hold down <b>[3]</b> for 1 second + <b>[ZONE NUMBER] + [*]</b>
Program buzz zone	Hold down <b>[4]</b> for 1 second + <b>[ZONE NUMBER] + [*]</b>
View Trouble Status	Hold down <b>[7]</b> for 1 second
Duress	<b>[#] + [DURESS CODE]</b>



# Warranty

Inhep Electronics Holdings (Pty) Ltd guarantees all IDS Control Panels against defective parts and workmanship for 24 months from date of purchase. Inhep Electronics Holdings shall, at its option, repair or replace the defective equipment upon the return of such equipment to any Inhep Electronics Holdings branch. This warranty applies **ONLY** to defects in components and workmanship and **NOT** to damage due to causes beyond the control of Inhep Electronics Holdings, such as incorrect voltage, lightning damage, mechanical shock, water damage, fire damage, or damage arising out of abuse and improper application of the equipment.

**NOTE:** Wherever possible, return only the PCB to Inhep Electronics Holdings service Centres.  
DO NOT return the metal enclosure.

The **IDS 805** is a product of **IDS (Inhep Digital Security)**  
and is manufactured by  
**Inhep Electronics Holdings (Pty) Ltd**

## **WARNING**

**For safety reasons, only connect equipment with a telecommunications compliance label. This includes customer equipment previously labelled permitted or certified.**

91 Escom Road • New Germany • 3610 • South Africa  
P O Box 738 • New Germany • 3620 • South Africa  
Tel: +27 (0)31 705 1373 • Fax: +27 (0)31 705 4445  
e-mail: [info@inhep.com](mailto:info@inhep.com) • [www.inhep.com](http://www.inhep.com)

INHEP ELECTRONICS HOLDINGS (Pty) Ltd  
Reg. No. 2007/002578/07

